

Spaceport America Cup

Intercollegiate Rocket Engineering Competition Design, Test, & Evaluation Guide

Table of Contents

SECTION	PAGE
1.0 INTRODUCTION	5
1.1 BACKGROUND	5
1.2 PURPOSE AND SCOPE	5
1.3 CONVENTION AND NOTATION	5
1.4 REVISION	6
1.5 DOCUMENTATION	6
2.0 PROPULSION SYSTEMS	7
2.1 NON-TOXIC PROPELLANTS	7
2.2 PROPULSION SYSTEM SAFING AND ARMING	7
2.2.1 GROUND-START IGNITION CIRCUIT ARMING	7
2.2.2 AIR-START IGNITION CIRCUIT ARMING	7
2.2.3 PROPELLANT OFFLOADING AFTER LAUNCH ABORT	7
2.3 AIR-START IGNITION CIRCUIT ELECTRONICS	7
2.4 SRAD PROPULSION SYSTEM TESTING	8
2.4.1 COMBUSTION CHAMBER PRESSURE TESTING	8
2.4.2 HYBRID AND LIQUID PROPULSION SYSTEM TANKING TESTING	8
2.4.3 STATIC HOT-FIRE TESTING	8
3.0 RECOVERY SYSTEMS AND AVIONICS	8
3.1 DUAL-EVENT PARACHUTE AND PARAFOIL RECOVERY	8
3.1.1 INITIAL DEPLOYMENT EVENT	8
3.1.2 MAIN DEPLOYMENT EVENT	9
3.1.3 EJECTION GAS PROTECTION	9
3.1.4 PARACHUTE SWIVEL LINKS	9
3.1.5 PARACHUTE COLORATION AND MARKINGS	9
3.2 NON-PARACHUTE/PARAFOIL RECOVERY SYSTEMS	9
3.3 REDUNDANT ELECTRONICS	9
3.3.1 REDUNDANT COTS RECOVERY ELECTRONICS	9

3.3.2	DISSIMILAR REDUNDANT RECOVERY ELECTRONICS	10
3.4	SAFETY CRITICAL WIRING	10
3.4.1	CABLE MANAGEMENT	10
3.4.2	SECURE CONNECTIONS	10
3.5	RECOVERY SYSTEM ENERGETIC DEVICES	10
3.6	RECOVERY SYSTEM TESTING	10
3.6.1	GROUND TEST DEMONSTRATION	10
3.6.2	OPTIONAL FLIGHT TEST DEMONSTRATION	10
4.0	STORED-ENERGY DEVICES	11
4.1	ENERGETIC DEVICE SAFING AND ARMING	11
4.1.1	ARMING DEVICE ACCESS	11
4.1.2	ARMING DEVICE LOCATION	11
4.2	SRAD PRESSURE VESSELS	12
4.2.1	RELIEF DEVICE	12
4.2.2	DESIGNED BURST PRESSURE FOR METALLIC PRESSURE VESSELS	12
4.2.3	DESIGNED BURST PRESSURE FOR COMPOSITE PRESSURE VESSELS	12
4.2.4	SRAD PRESSURE VESSEL TESTING	12
5.0	ACTIVE FLIGHT CONTROL SYSTEMS	13
5.1	RESTRICTED CONTROL FUNCTIONALITY	13
5.2	UNNECESSARY FOR STABLE FLIGHT	13
5.3	DESIGNED TO FAIL SAFE	13
5.4	BOOST PHASE DORMANCY	13
5.5	ACTIVE FLIGHT CONTROL SYSTEM ELECTRONICS	13
5.6	ACTIVE FLIGHT CONTROL SYSTEM ENERGETICS	13
6.0	AIRFRAME STRUCTURES	14
6.1	ADEQUATE VENTING	14
6.2	OVERALL STRUCTURAL INTEGRITY	14
6.2.1	MATERIAL SELECTION	14
6.2.2	LOAD BEARING EYEBOLTS AND U-BOLTS	14
6.2.3	IMPLEMENTING COUPLING TUBES	14
6.2.4	LAUNCH LUG MECHANICAL ATTACHMENT	14

6.2.5	AFT MOST LAUNCH LUG	14
6.3	RF TRANSPARENCY	14
6.3.1	RF WINDOW LOCATION	15
6.3.2	RF WINDOW DIMENSIONS	15
6.4	IDENTIFYING MARKINGS	15
6.5	OTHER MARKINGS	15
7.0	PAYLOAD	15
7.1	PAYLOAD RECOVERY	15
7.1.1	PAYLOAD RECOVERY SYSTEM ELECTRONICS AND SAFETY CRITICAL WIRING	16
7.1.2	PAYLOAD RECOVERY SYSTEM TESTING	16
7.2	PAYLOAD ENERGETIC DEVICES	16
8.0	LAUNCH AND ASCENT TRAJECTORY REQUIREMENTS	16
8.1	LAUNCH AZIMUTH AND ELEVATION	16
8.2	LAUNCH STABILITY	16
8.3	ASCENT STABILITY	16
8.4	OVER STABILITY	16
9.0	ESRA PROVIDED LAUNCH SUPPORT EQUIPMENT	17
9.1	ESRA-PROVIDED LAUNCH RAILS	17
9.2	ESRA-PROVIDED LAUNCH CONTROL SYSTEM	17
10.0	TEAM-PROVIDED LAUNCH SUPPORT EQUIPMENT	17
10.1	EQUIPMENT PORTABILITY	17
10.2	LAUNCH RAIL ELEVATION	17
10.3	OPERATIONAL RANGE	17
10.4	FAULT TOLERANCE AND ARMING	17
10.5	SAFETY CRITICAL SWITCHES	18
	APPENDIX A: ACRONYMS, ABBREVIATIONS, AND TERMS	19
	APPENDIX B: SAFETY CRITICAL WIRING GUIDELINES	21
	APPENDIX C: FIRE CONTROL SYSTEM DESIGN GUIDELINES	25

1.0 INTRODUCTION

The Experimental Sounding Rocket Association (ESRA) and the New Mexico Spaceport Authority (aka Spaceport America; NMSA) have partnered to host and support the Spaceport America Cup (SA Cup), a week-long series of events which will set the background and provide structure for the world's largest university rocket engineering competition. This new host-event continues the Intercollegiate Rocket Engineering Competition's (IREC) legacy of inspiring student design teams from across the country and around the world.

1.1 BACKGROUND

The “smoke and fire,” noise, high speeds, and sleek aerodynamics of rocketry encourage students to pursue science, technology, and mathematics-based careers. They have "Rocket Fever!", and competition motivates them to extend themselves beyond the classroom to design and build the rockets themselves. These students also learn to work as a team, solving real world problems under the same pressures they'll experience in their future careers.

ESRA held the first annual IREC in 2006. The competition achieved international status in 2011 when Canadian and Brazilian universities threw their hats in the ring. These schools have since been joined by others from every continent except Antarctica. In fact, the competition has roughly doubled in size every year since 2013, becoming the largest known collegiate level rocket engineering competition in the world in 2014. Attendance in 2016 included as many as 600 participants – including faculty, family, and friends of students from over 50 colleges and universities. The next year marked the start of a new era with the inaugural SA Cup. Over 1,100 students and representatives from 22 industry partners participated in an academic conference, rocket and payload engineering competitions, and non-competing demonstration flight tests. The cup continues to grow with over 150 teams competing in 2020.

1.2 PURPOSE AND SCOPE

This document defines the minimum design, test, and evaluation criteria the event organizers expect IREC teams to meet before launching at the SA Cup. The event organizers use these criteria to promote flight safety. Departures from the guidance this document provides may negatively impact an offending team's score and flight status, depending on the degree of severity. The foundational, qualifying criteria for the IREC are contained in the *IREC Rules & Requirement Document*.

This document incorporates the *Tripoli Rocketry Association (TRA) Safety Code*, the *National Fire Protection Association (NFPA) Code for High Power Rocketry (NFPA 1127)*, and ESRA's observations on student launch initiatives. Although NFPA 1127, Section 1.3.3 exempts colleges and universities from its contents, and ESRA has no formal affiliation with the TRA, these documents remain excellent supplemental resources for student researchers to learn more about best practices adopted by the amateur high-power rocketry community.

IREC teams should avoid feeling constrained before seeking clarification, and may contact ESRA with questions or concerns regarding their project plans' alignment with the spirit and intent of the *IREC Design, Test, & Evaluation Guide (DTEG)*.

1.3 CONVENTION AND NOTATION

The following definitions differentiate between requirements and other statements. The degree to which a team satisfies the spirit and intent of these statements will guide the competition officials' decisions on a project's overall score in the IREC and flight status at the SA Cup.

Shall: This is the only verb used to denote mandatory requirements. Failure to satisfy the spirit and intent of a mandatory requirement will always affect a project's score and flight status.

Should: This verb is used for stating non-mandatory goals. Failure to satisfy the spirit and intent of a non-mandatory goal may affect a project's score and flight status, depending on design implementation and the team's ability to provide thorough documentary evidence of their due diligence on-demand.

Will: This verb is used for stating facts and declarations of purpose. The authors' use these statements to clarify the spirit and intent of requirements and goals.

Flight status refers to the granting of permission to attempt flight, and the provisions under which that permission remains valid. A project's flight status may be either nominal, provisional, or denied.

Nominal: A project assigned nominal flight status meets or exceeds the minimum expectations of this document and reveals no obvious flight safety concerns during flight safety review at the SA Cup.

Provisional: A project assigned provisional flight status generally meets the minimum expectations of this document, but reveals flight safety concerns during flight safety review at the SA Cup which may be mitigated by field modification or by adjusting launch environment constraints. Launch may occur only when the prescribed provisions are met.

Denied: Competition officials reserve the right to deny flight status to any project which fails to meet the minimum expectations of this document, or reveals un-mitigatable flight safety concerns during flight safety review at the SA Cup.

An effort is made throughout this document to differentiate between launch vehicle and payload associated systems. Unless otherwise stated, requirements referring only to the launch vehicle do not apply to payloads and vice versa.

1.4 REVISION

It is expected the *IREC DTEG* may require revision from one competition to the next, based on the lessons learned by both host organizations and the participants. Major revisions will be accomplished by complete document reissue. "Real world events" may require smaller revisions to this document in the months leading up to a competition. Such revisions will be reflected in updates to the document's effective date. The authority to issue revised versions of this document rests with ESRA and NMSA. Revisions will be approved either by ESRA, or jointly by both organizations as appropriate.

1.5 DOCUMENTATION

The following documents include standards, guidelines, schedules, or required standard forms. The documents listed in this section are either applicable to the extend specified in this document, or contain reference information useful in the application of this document.

DOCUMENT	FILE LOCATION
IREC Rules & Requirements Document	http://www.soundingrocket.org/sa-cup-documents--forms.html
SA Cup Integrated Master Schedule Document	http://www.soundingrocket.org/sa-cup-documents--forms.html
SA Cup Range Standard Operating Procedures	http://www.soundingrocket.org/sa-cup-documents--forms.html
IREC Entry Form & Progress Update	http://www.soundingrocket.org/sa-cup-documents--forms.html
TRA Safety Code	http://www.tripoli.org/SafetyCode
NFPA 1127: Code for High-Power Rocketry	http://unh.edu/rocketcats/NFPA-1127.pdf
14 CFR, Part 1, 1.1 General Definitions	http://www.ecfr.gov/cgi-bin/text-idx?SID=795aaa37494b6c99641135267af8161e&mc=true&node=se14.1.1_11&rgn=div8
14 CFR, Part 101, Subpart C, 101.22 Definitions	http://www.ecfr.gov/cgi-bin/text-idx?SID=795aaa37494b6c99641135267af8161e&mc=true&node=se14.2.101_122&rgn=div8

2.0 PROPULSION SYSTEMS

2.1 NON-TOXIC PROPELLANTS

Launch vehicles entered the IREC shall use non-toxic propellants. Ammonium perchlorate composite propellant (APCP), potassium nitrate and sugar (aka "rocket candy"), nitrous oxide, liquid oxygen (LOX), hydrogen peroxide, kerosene, propane, alcohol, and similar substances, are all considered non-toxic. Toxic propellants are defined as those requiring breathing apparatus, unique storage and transport infrastructure, extensive personal protective equipment (PPE), etc.

2.2 PROPULSION SYSTEM SAFING AND ARMING

A propulsion system is considered armed if only one action (eg an ignition signal) must occur for the propellant(s) to ignite. The "arming action" is usually something (ie a switch in series) that enables an ignition signal to ignite the propellant(s). For example, a software-based control circuit that automatically cycles through an "arm function" and an "ignition function" does not, in fact, implement arming. In this case, the software's arm function does not prevent a single action (eg starting the launch software) from causing unauthorized ignition. This problem may be avoided by including a manual interrupt in the software program.

The ESRA provided launch control system described in Section 9.2 of this document provides sufficient propulsion system arming functionality for almost all launch vehicles using single stage, solid rocket propulsion systems. Therefore, these requirements generally concern more complex propulsion systems (ie hybrid, liquid, and multistage systems) and all team provided launch control systems. Additional requirements for team provided launch control systems are defined in Section 10.0 of this document.

2.2.1 GROUND-START IGNITION CIRCUIT ARMING

All ground-started propulsion system ignition circuits/sequences shall not be "armed" until all personnel are at least 50 ft (15 m) away from the launch vehicle. The ESRA provided launch control system satisfies this requirement by implementing a remote "Pad HOT" sequence initiated from LCO.

2.2.2 AIR-START IGNITION CIRCUIT ARMING

All upper-stage (i.e., air-starts) propulsion systems shall be designed to prevent motor ignition during arming on the ground, inhibit motor ignition in the event of a non-nominal flight, and be capable of being disarmed in the event the rocket is not launched. See Section 2.3 for specific requirements for air-start ignition circuits.

2.2.3 PROPELLANT OFFLOADING AFTER LAUNCH ABORT

Hybrid and liquid propulsion systems shall implement a means for remotely controlled venting or offloading of all liquid and gaseous propellants in the event of a launch abort.

2.3 AIR-START IGNITION CIRCUIT ELECTRONICS

All upper-stage ignition systems shall comply with the same requirements and goals for "safety critical wiring" as recovery systems. These requirements and goals are defined in Section 3.4 of this document.

Staged flights shall have a minimum thrust-to-weight ratio of 8 on the boost. The sustainer shall have a minimum thrust-to-weight ratio of 3. Clustered rockets shall have a minimum thrust-to-weight ratio of 6 on any motor that is ignited on the pad (i.e., the rocket must be able to fly safely if only one of the multiple motors lights).

2.3.1 AIR-START FLIGHT COMPUTER REQUIREMENTS

Ignition of air-start motors shall be accomplished using a COTS flight computer that has the capability of performing an "altitude check" that can inhibit air-start ignition below a pre-selected altitude. Currently available flight computers that have this capability include, but are not limited to, Featherweight "Raven", Altus Metrum "Telemega" and "EasyMega", and MARSAs Systems "MARSAs 54" or "MARSAs 33". Home-assembled flight computers are not allowed for the purpose of igniting air-start motors. Redundant flight computers can be used for air-start ignition, but are neither required nor recommended. Simple timers are prohibited except when used in combination with altitude or tilt lockout.

Flight computers that inhibit air-start motor ignition using angle from vertical (tilt) are encouraged. Currently available flight computers that have this capability include, but are not limited to, Altus Metrum "TeleMega" and "EasyMega", MARSAs Systems Tilt Module & Interface with either the MARSAs 54 or MARSAs 33 flight computers, and Multitronix "Kate 2". Projects using tilt may be allowed to launch at an elevation of $87^{\circ}+1^{\circ}$, rather than at $84^{\circ}+1^{\circ}$, at the discretion of launch officials. "Demonstration" high altitude projects that are projected to fly in excess of 30,000 feet must utilize tilt inhibition (in addition to altitude lockout).

2.3.2 AIR-START FLIGHTS – ARMING PROCEDURES

All projects must have provisions capable of preventing air-start motor ignition on the ground. A provision to open the circuit between the flight computer and the initiator during power-up of the flight computer is mandatory. Shunts are recommended but are not required. Examples of recommended switch designs are provided in Appendix D.

Flight computers shall not be armed until the rocket is in a vertical position. The electronics configuration shall be designed such that the provision used to open the circuit to the initiator can be used to again open the circuit to the initiator in the event that the rocket is not launched.

2.3.3 AIR-START FLIGHTS – MOTOR INHIBITION DURING FLIGHT

The flight computer controlling air-start motor ignition shall be configured to inhibit ignition of the air-start motor unless booster burnout has been detected and the rocket has reached an altitude of at least 80% of the simulated altitude at the time when initiator firing is desired. The flight computer shall be configured to prevent the air-start motor from firing at a later time if the altitude threshold was not achieved.

2.3.4 AIR-START FLIGHTS – ADDITIONAL INFORMATION REQUIREMENTS

Teams shall provide additional information in progress update reports specifically related to air-start flights. The information specified below will be provided as part of the 2nd Progress Update (due March 6, 2020). Updated information, including a response to ESRA comments is applicable, shall be included in the 3rd Progress Update (due May 15, 2020). The required information includes the following:

- Schematic diagram of the electronics configuration to be used for air-start motor ignition and recovery;
- A graph illustrating flight simulation profile, to include altitude, velocity and acceleration as a function of time to the expected apogee time;
- An explanation of strategy for the flight based on the above flight profile (i.e., what is the rationale behind the selection of staging times, coast times, etc.);
- A description of specific procedures that will be used to prevent air-start motor ignition on the ground;
- A description of specific procedures that will be used to inhibit air-start motor ignition in the event of a non-nominal flight; and
- Drawing & description of the interstage coupler.

2.4 SRAD PROPULSION SYSTEM TESTING

Teams shall comply with all rules, regulations, and best practices imposed by the authorities at their chosen test location(s). The following requirements concern verification testing of student researched and developed (SRAD) and modified commercial-off-the-shelf (COTS) propulsion systems. ESRA recommends teams complete these tests by April 1st of the competition year. See Section 2.4.3 for further information on this.

2.4.1 COMBUSTION CHAMBER PRESSURE TESTING

SRAD and modified COTS propulsion system combustion chambers shall be designed and tested according to the SRAD pressure vessel requirements defined in Section 4.2 of this document. Note that combustion chambers are exempted from the requirement for a relief device.

2.4.2 HYBRID AND LIQUID PROPULSION SYSTEM TANKING TESTING

SRAD and modified COTS propulsion systems using liquid propellant(s) shall successfully (without significant anomalies) complete a propellant loading and off-loading test in "launch-configuration". This test may be conducted using either actual propellant(s) or suitable proxy fluids. Links to videos and testing data should be posted in your final report.

2.4.3 STATIC HOT-FIRE TESTING

SRAD propulsion systems shall successfully (without significant anomalies) complete an instrumented (chamber pressure and/or thrust), full scale (including system working time) static hot-fire test prior to the IREC. Teams must provide a BurnSim file of their intended SRAD motor along with static test data and that included a graph of the pressure & thrust over time. A link to a video of successful testing should be included in your final report. All SRAD motors must be designed and manufactured by the team. No second party motors are permitted under any circumstances. The flight motor must represent the static test motor in all respects. Any changes to the SRAD flight motor must be tested and resubmitted. No Exceptions.

3.0 RECOVERY SYSTEMS AND AVIONICS

3.1 DUAL-EVENT PARACHUTE AND PARAFoil RECOVERY

Each independently recovered launch vehicle body anticipated to reach an apogee above 1,500 ft (457 m) above ground level (AGL) shall follow a "dual-event" recovery operations concept (CONOPS), including an initial deployment event (eg a drogue parachute deployment; reefed main parachute deployment) and a main deployment event (eg a main parachute deployment; main parachute un-reefing). Independently recovered bodies whose apogee is not anticipated to exceed 1,500 ft (457 m) AGL are exempted, and may feature only a single/main deployment event.

The Jolly Logic Chute Release (JLCR) is NOT considered to be "redundant electronics" and will not be permitted to be used for any main parachute or other recovery event.

3.1.1 INITIAL DEPLOYMENT EVENT

The initial deployment event shall occur at or near apogee, stabilize the vehicle's attitude (ie prevent or eliminate ballistic re-entry), and reduce its descent rate enough to permit a successful main deployment event yet not so much as to exacerbate wind drift (eg between 75 and 150 ft/s [23-46 m/s]).

3.1.2 MAIN DEPLOYMENT EVENT

The main deployment event shall occur at an altitude no higher than 1,500 ft (457 m) AGL and reduce the vehicle's descent rate sufficiently to prevent excessive damage upon impact with ground (ie less than 30 ft/s [9 m/s]). The Jolly Logic Chute Release (JLCR) is NOT considered to be "redundant electronics" and will not be permitted to be used for any main parachute or other recovery event.

3.1.3 EJECTION GAS PROTECTION

The recovery system shall implement adequate protection (eg fire resistant material, pistons, baffles etc...) to prevent hot ejection gases (if implemented) from causing burn damage to retaining chords, parachutes, and other vital components as the specific design demands.

3.1.4 PARACHUTE SWIVEL LINKS

The recovery system rigging (eg parachute lines, risers, shock chords, etc...) shall implement appropriately rated swivel links at connections to relieve twist/torsion as the specific design demands. This will mitigate the risk of torque loads unthreading bolted connections during recovery.

3.1.5 PARACHUTE COLORATION AND MARKINGS

When separate parachutes are used for the initial and main deployment events, **these parachutes should be highly dissimilar from one another visually**. This is typically achieved by using parachutes whose primary colors contrast those of the other chute. This will enable ground-based observers to more easily characterize deployment events with high-power optics.

3.2 NON-PARACHUTE/PARAFoil RECOVERY SYSTEMS

Teams exploring other (ie non-parachute or parafoil based) recovery methods shall notify ESRA of their intentions at the earliest possible opportunity, and keep ESRA apprised of the situation as their work progresses. ESRA may make additional requests for information and draft unique requirements depending on the team's specific design implementation. Range Safety personnel can deem the design as unsafe if they feel there is a possibility the recovery could possibly depart the recovery area.

3.3 REDUNDANT ELECTRONICS

Launch vehicles shall implement redundant recovery system electronics, including sensors/flight computers and "electric initiators"—assuring initiation by a backup system, with a separate power supply (ie battery), if the primary system fails. In this context, electric initiator is the device energized by the sensor electronics, which then initiates some other mechanical or chemical energy release to deploy its portion of the recovery system (i.e. electric matches, nichrome wire, flash bulbs, etc...).

3.3.1 REDUNDANT COTS RECOVERY ELECTRONICS

At least one redundant recovery system electronics subsystem shall implement a COTS flight computer (eg StratoLogger, G-Wiz, Raven, Parrot, AIM, EasyMini, TeleMetrum, RRC3, etc...). This flight computer may also serve as the official altitude logging system specified in Section 2.5 of the *IREC Rules & Requirements Document*.

To be considered COTS, the flight computer (including flight software) must have been developed and validated by a commercial third party. **Commercially designed flight computer “kits” (eg the Eggtimer or similar) are not permitted as COTS**. Flight computer “kits” may be used as secondary or tertiary electronics. Any student developed flight computer assembled from separate COTS components will not be considered a COTS system. Similarly, any COTS microcontroller running student developed flight software will not be considered a COTS system. Student modifications to the base software or hardware of a COTS flight controller will be considered an SRAD upgrade.

3.3.2 DISIMILAR REDUNDANT RECOVERY ELECTRONICS

There is no requirement that the redundant/backup system be dissimilar to the primary; however, there are advantages to using dissimilar primary and backup systems. Such configurations are less vulnerable to any inherent environmental sensitivities, design, or production flaws affecting a particular component.

3.4 SAFETY CRITICAL WIRING

For the purposes of this document, safety critical wiring is defined as electrical wiring associated with recovery system deployment events and any "air started" rocket motors. In addition to the following requirement statements, all safety critical wiring should follow the safety critical wiring guidelines described in Appendix B of this document.

3.4.1 CABLE MANAGEMENT

All safety critical wiring shall implement a cable management solution (e.g. wire ties, wiring, harnesses, cable raceways) which will prevent tangling and excessive free movement of significant wiring/cable lengths due to expected launch loads. This requirement is not intended to negate the small amount of slack necessary at all connections/terminals to prevent unintentional de-mating due to expected launch loads transferred into wiring/cables at physical interfaces.

3.4.2 SECURE CONNECTIONS

All safety critical wiring/cable connections shall be sufficiently secure as to prevent de-mating due to expected launch loads. This will be evaluated by a "tug test", in which the connection is gently but firmly "tugged" by hand to verify it is unlikely to break free in flight.

3.5 RECOVERY SYSTEM ENERGETIC DEVICES

All stored-energy devices (aka energetics) used in recovery systems shall comply with the energetic device requirements defined in Section 4.0 of this document.

3.6 RECOVERY SYSTEM TESTING

Teams shall comply with all rules, regulations, and best practices imposed by the authorities at their chosen test location(s). The following requirements concern verification testing of all recovery systems. ESRA recommends teams complete these tests by 01 April. While not a requirement, this date is recommended to assure teams are prepared for the IREC.

3.6.1 GROUND TEST DEMONSTRATION

All recovery system mechanisms shall be successfully (without significant anomalies) tested prior to the IREC, either by flight testing, or through one or more ground tests of key subsystems. In the case of such ground tests, sensor electronics will be functionally included in the demonstration by simulating the environmental conditions under which their deployment function is triggered. A link to all video of the testing cycle(s) should be included in the final report.

3.6.2 OPTIONAL FLIGHT TEST DEMONSTRATION

All recovery system mechanisms shall be successfully (without significant anomalies) tested prior to the IREC, either by flight testing, or through one or more ground tests of key subsystems. While not required, a flight test demonstration may be used in place of ground testing. In the case of such a flight test, the recovery system flown will verify the intended design by implementing the same major subsystem components (eg flight computers and parachutes) as will be integrated into the launch vehicle intended for the IREC (ie a surrogate booster may be used). A link to a video of the test flight should be included in the final report.

4.0 STORED-ENERGY DEVICES

4.1 ENERGETIC DEVICE SAFING AND ARMING

All energetics shall be safed until the rocket is in the launch position, at which point they may be "armed". An energetic device is considered safed when two separate events are necessary to release the energy. An energetic device is considered armed when only one event is necessary to release the energy. For the purpose of this document, energetics are defined as all stored-energy devices – other than propulsion systems – that have reasonable

potential to cause bodily injury upon energy release. The following table lists some common types of stored-energy devices and overviews in what configuration they are considered non-energetic, safed, or armed.

DEVICE CLASS	NON-ENERGETIC	SAFED	ARMED
Igniters/Squibs	Small igniters/squibs, nichrome, wire or similar	Large igniters with leads shunted	Large igniters with no-shunted leads
Pyrogens (eg black powder)	Very small quantities contained in non-shrapnel producing devices (eg pyro-cutters or pyro-valves)	Large quantities with no igniter, shunted igniter leads, or igniter(s) connected to unpowered avionics	Large quantities with non-shunted igniter or igniter(s) connected to powered avionics
Mechanical Devices (eg powerful springs)	De-energized/relaxed state, small devices, or captured devices (ie no jettisoned parts)	Mechanically locked and not releasable by a single event	Unlocked and releasable by a single event
Pressure Vessels	Non-charged pressure vessels	Charged vessels with two events required to open main valve	Charged vessels with one event required to open main valve

Although these definitions are consistent with the propulsion system arming definition provided in Section 2.0 of this document, this requirement is directed mainly at the energetics used by recovery systems and extends to all other energetics used in experiments, control systems, etc. Note that while Section 2.2.1 requires propulsion systems be armed only after the launch rail area is evacuated to a specified distance, while this requirement permits personnel to arm other stored-energy devices at the launch rail. Teams should not bring excessive amounts of pyrogenic materials to the event. If your rocket requires a total of 12g of BP or Pyrogen, please do not transport a large container to the event. A smaller plastic container would be most appropriate.

4.1.1 ARMING DEVICE ACCESS

All energetic device arming features shall be externally accessible/controllable. This does not preclude the limited use of access panels which may be secured for flight while the vehicle is in the launch position.

4.1.2 ARMING DEVICE LOCATION

All energetic device arming features shall be located on the airframe such that any inadvertent energy release by these devices will not impact personnel arming them. For example, the arming key switch for an energetic device used to deploy a hatch panel shall not be located at the same airframe clocking position as the hatch panel deployed by that charge.

4.2 SRAD PRESSURE VESSELS

The following requirements concern design and verification testing of SRAD and modified COTS pressure vessels. Unmodified COTS pressure vessels utilized for other than their advertised specifications will be considered modified, and subject to these requirements. SRAD (including modified COTS) rocket motor propulsion system combustion chambers are included as well but, are exempted from the relief device requirement.

4.2.1 RELIEF DEVICE

SRAD pressure vessels shall implement a relief device, set to open at no greater than the proof pressure specified in the following requirements. SRAD (including modified COTS) rocket motor propulsion system combustion chambers are exempted from this requirement.

4.2.2 **DESIGNED BURST PRESSURE FOR METALLIC PRESSURE VESSELS**

SRAD and modified COTS pressure vessels constructed entirely from isentropic materials (eg metals) shall be designed to a burst pressure no less than 2 times the maximum expected operating pressure, where the maximum operating pressure is the maximum pressure expected during pre-launch, flight, and recovery operations.

4.2.3 **DESIGNED BURST PRESSURE FOR COMPOSITE PRESSURE VESSELS**

All SRAD and modified COTS pressure vessels either constructed entirely from non-isentropic materials (eg fiber reinforced plastics; FRP; aka composites), or implementing composite overwrap of a metallic vessel (aka composite overwrapped pressure vessels; COPV), shall be designed to a burst pressure no less than 3 times the maximum expected operating pressure, where the maximum operating pressure is the maximum pressure expected during pre-launch, flight, and recovery operations.

4.2.4 **SRAD PRESSURE VESSEL TESTING**

Teams shall comply with all rules, regulations, and best practices imposed by the authorities at their chosen test location(s). The following requirements concern design and verification testing of SRAD and modified COTS pressure vessels. Unmodified COTS pressure vessels utilized for other than their advertised specifications will be considered modified, and subject to these requirements. SRAD (including modified COTS) rocket motor propulsion system combustion chambers are included as well. ESRA recommends teams complete these tests by 01 April. While not a requirement, this date is recommended to assure teams are prepared for the IREC.

4.2.4.1 **PROOF PRESSURE TESTING**

SRAD and modified COTS pressure vessels shall be proof pressure tested successfully (without significant anomalies) tested to 1.5 times the maximum expected operating pressure for no less than twice the maximum expected system working time, using the intended flight article(s) (eg the pressure vessel(s) used in proof testing must be the same one(s) flown at the IREC). The maximum system working time is defined as the maximum uninterrupted time duration the vessel will remain pressurized during pre-launch, flight, and recovery operations.

4.2.4.2 **OPTIONAL BURST PRESSURE TESTING**

Although there is no requirement for burst pressure testing, a rigorous verification & validation test plan typically includes a series of both non-destructive (ie proof pressure) and destructive (ie burst pressure) tests. A series of burst pressure tests performed on the intended design will be viewed favorably; however, this will not be considered an alternative to proof pressure testing of the intended flight article.

4.2.4.3 **USE OF PYROTECHNICS IN PAYLOADS**

Payloads **MAY NOT** include any form of pyrotechnics. These include but are not limited to: rocket motors, exploding bolts, or other energetics.

5.0 **ACTIVE FLIGHT CONTROL SYSTEMS**

5.1 **RESTRICTED CONTROL FUNCTIONALITY**

Launch vehicle active flight control systems shall be optionally implemented strictly for pitch and/or roll stability augmentation, or for aerodynamic "braking". Under no circumstances will a launch vehicle entered in the IREC be actively guided towards a designated spatial target. ESRA may make additional requests for information and draft unique requirements depending on the team's specific design implementation.

5.2 UNNECESSARY FOR STABLE FLIGHT

Launch vehicles implementing active flight controls shall be naturally stable without these controls being implemented (eg the launch vehicle may be flown with the control actuator system [CAS] – including any control surfaces – either removed or rendered inert and mechanically locked, without becoming unstable during ascent).

Attitude control systems (ACS) will serve only to mitigate the small perturbations which affect the trajectory of a stable rocket that implements only fixed aerodynamic surfaces for stability. Stability is defined in Section 8.3 of this document. ESRA may make additional requests for information and draft unique requirements depending on the team's specific design implementation.

5.3 DESIGNED TO FAIL SAFE

Control actuator systems (CAS) shall mechanically lock in a neutral state whenever either an abort signal is received for any reason, primary system power is lost, or the launch vehicle's attitude exceeds 30° from its launch elevation. Any one of these conditions being met will trigger the fail safe, neutral system state. A neutral state is defined as one which does not apply any moments to the launch vehicle (eg aerodynamic surfaces trimmed or retracted, gas jets off, etc...).

5.4 BOOST PHASE DORMANCY

CAS shall mechanically lock in a neutral state – defined in Section 5.3 of this document – until either the mission's boost phase has ended (ie all propulsive stages have ceased producing thrust), the launch vehicle has crossed the point of maximum aerodynamic pressure (aka max Q) in its trajectory, or the launch vehicle has reached an altitude of 20,000 ft (6,096 m) AGL. Any one of these conditions being met will permit the active system state. A neutral state is defined as one which does not apply any moments to the launch vehicle (eg aerodynamic surfaces trimmed or retracted, gas jets off, etc...).

5.5 ACTIVE FLIGHT CONTROL SYSTEM ELECTRONICS

Wherever possible, all active control systems should comply with requirements and goals for "redundant electronics" and "safety critical wiring" as recovery systems—understanding that in this case "initiation" refers CAS commanding rather than a recovery event. These requirements and goals are defined in Sections 3.3 (except 3.3.1) and 3.4 respectively of this document. Flight control systems are exempt from the requirement for COTS redundancy, given that such components are generally unavailable as COTS to the amateur high-power rocketry community.

5.6 ACTIVE FLIGHT CONTROL SYSTEM ENERGETICS

All stored-energy devices used in an active flight control system (aka energetics) shall comply with the energetic device requirements defined in Section 4.0 of this document.

6.0 AIRFRAME STRUCTURES

6.1 ADEQUATE VENTING

Launch vehicles shall be adequately vented to prevent unintended internal pressures developed during flight from causing either damage to the airframe or any other unplanned configuration changes. Typically, a 1/8 to 3/16 inch (0.318 to 0.476 cm) hole is drilled in the booster section just behind the nosecone or payload shoulder area, and through the hull or bulkhead of any similarly isolated compartment/bay.

6.2 OVERALL STRUCTURAL INTEGRITY

Launch vehicles will be constructed to withstand the operating stresses and retain structural integrity under the conditions encountered during handling as well as rocket flight. The following requirements address some key points applicable to almost all amateur high power rockets, but are not exhaustive of the conditions affecting each unique design. Student teams are ultimately responsible for thoroughly understanding, analyzing, and mitigating their design's unique load set.

6.2.1 MATERIAL SELECTION

PVC (and similar low-temperature polymers), Public Missiles Ltd. (PML) Quantum Tube, and stainless steel components shall not be used in any structural (ie load bearing) capacity, most notably as load bearing eyebolts, launch vehicle airframes, or propulsion system combustion chambers.

6.2.2 LOAD BEARING EYEBOLTS AND U-BOLTS

All load bearing eyebolts shall be of the closed-eye, forged type – NOT of the open eye, bent wire type. Furthermore, all load bearing eyebolts and U-Bolts shall be steel (other than stainless). This requirement extends to any bolt and eye-nut assembly used in place of an eyebolt.

6.2.3 IMPLEMENTING COUPLING TUBES

Airframe joints which implement "coupling tubes" should be designed such that the coupling tube extends no less than one body caliber on either side of the joint – measured from the separation plane. Regardless of implementation (eg RADAX or other joint types) airframe joints will be "stiff" (ie prevent bending).

6.2.4 LAUNCH LUG MECHANICAL ATTACHMENT

Launch lugs (aka rail guides) should implement "hard points" for mechanical attachment to the launch vehicle airframe. These hardened/reinforced areas on the vehicle airframe, such as a block of wood installed on the airframe interior surface where each launch lug attaches, will assist in mitigating lug "tear outs" during operations. At the IREC, competition officials will require teams to lift their launch vehicles by the rail guides and/or demonstrate that the bottom guide can hold the vehicle's weight when vertical before permitting them to proceed with launch preparations.

6.2.5 AFT MOST LAUNCH LUG

The aft most launch lug shall support the launch vehicle's fully loaded launch weight while vertical. At the IREC, Competition officials will require teams to lift their launch vehicles by the rail guides and/or demonstrate that the bottom guide can hold the vehicle's weight when vertical before permitting them to proceed with launch preparations.

6.3 RF TRANSPARENCY

ESRA will begin a pilot program, starting with 30k or higher altitude flights, to alert for ballistic return of heavy components following recovery system failures using small ESRA provided telemetry beacons. This will require some IREC teams (and some non-competing projects asked to use this document) to implement radio frequency (RF) transparent "windows" at the top of the motor mount and near the greatest concentration of payload mass. The following requirements will describe these windows to facilitate internal placement of the ESRA provided beacons.

Although the result of this pilot program may have some inherent utility to recovery, it DOES NOT exempt affected teams from the requirement for team provided recovery tracking beacon(s) defined in Section 2.4 of the *IREC Rules & Requirements Document*.

6.3.1 RF WINDOW LOCATION

All launch vehicles entered in one of the three “30K IREC categories” shall provide two radio RF transparent “windows” (eg fiberglass airframe tube sections) – one located at the top of the motor mount structure, and the other located at (or near) the greatest concentration of payload mass.

6.3.2 RF WINDOW DIMENSIONS

Each region of RF transparency shall extend 360° around the airframe and measure at least 6” in length. This will assure signal reception at the alert system base station through most of the flight, regardless of vehicle rotation.

6.4 IDENTIFYING MARKINGS

The team's Team ID (a number assigned by ESRA prior to the IREC), project name, and academic affiliation(s) shall be clearly identified on the launch vehicle airframe, nosecone and other locations where possible. The Team ID especially, will be prominently displayed (preferably visible on all four quadrants of the vehicle, as well as fore and aft), assisting competition officials to positively identify the project hardware with its respective team throughout the IREC. ESRA does not provide any guarantee that lost rockets may be recovered or returned to the teams after the competition has ended. If a rocket is found with identifying markings, every effort will be made to return the components to the team at the team’s expense.

6.5 OTHER MARKINGS

There are no requirements for airframe coloration or markings beyond those specified in Section 6.4 of this document; however, ESRA offers the following recommendations to student teams. Mostly white or lighter tinted color (eg yellow, red, orange, etc...) airframes are especially conducive to mitigating some of the solar heating experienced in the IREC launch environment. Furthermore, high-visibility schemes (eg high-contrast black, orange, red, etc...) and roll patterns (eg contrasting stripes, “V” or “Z” marks, etc..) may allow ground-based observers to more easily track and record the launch vehicle’s trajectory with high-power optics.

7.0 PAYLOAD

7.1 PAYLOAD RECOVERY

Payloads may be deployable or remain attached to the launch vehicle throughout the flight. Deployable payloads shall incorporate an independent recovery system, reducing the payload's descent velocity to less than 30 ft/s (9 m/s) before it descends through an altitude of 1,500 ft AGL.

Note that while deployable payloads implementing a parachute or parafoil based recovery system are not required to comply with the dual-event requirements described in Section 3.1 of this document (the intent being to accommodate certain science/engineering packages requiring extended mission time), teams are advised that any hardware drifting outside the safe recovery area or onto White Sands Missile Range (WSMR) must be either abandoned or recovered at the team's own expense. WSMR is located approximately 10 miles (16 km) East from the NMSA Vertical Launch Area (VLA).

7.1.1 PAYLOAD RECOVERY SYSTEM ELECTRONICS AND SAFETY CRITICAL WIRING

Payloads implementing independent recovery systems shall comply with the same requirements and goals as the launch vehicle for "redundant electronics" and "safety critical wiring". These requirements and goals are defined in Sections 3.3 and 3.4 respectively of this document.

7.1.2 PAYLOAD RECOVERY SYSTEM TESTING

Payloads implementing independent recovery systems shall comply with the same requirements and goals as the launch vehicle for "recovery system testing". These requirements and goals are defined in Section 3.6 of this document.

7.2 PAYLOAD ENERGETIC DEVICES

All stored-energy devices (aka energetics) used in payload systems shall comply with the energetic device requirements defined in Section 4.0 of this document.

8.0 LAUNCH AND ASCENT TRAJECTORY REQUIREMENTS

8.1 LAUNCH AZIMUTH AND ELEVATION

Launch vehicles shall nominally launch at an elevation angle of $84^{\circ} \pm 1^{\circ}$ and a launch azimuth defined by competition officials at the IREC. Competition officials reserve the right to require certain vehicles' launch elevation be as low 70° if possible flight safety issues are identified during pre-launch activities. **Competition officials may allow staged flights to launch at $87^{\circ} + 1^{\circ}$ if the rocket is using "tilt" to inhibit air-start motor ignition.**

8.2 LAUNCH STABILITY

Launch vehicles shall have sufficient velocity upon "departing the launch rail" to assure they will follow predictable flight paths. In lieu of detailed analysis, a rail departure velocity of at least 100 ft/s (30.5 m/s) is generally acceptable. Alternatively, the team may use detailed analysis to prove stability is achieved at a lower rail departure velocity (greater than 50 ft/s [15.24 m/s]) either theoretically (eg computer simulation) or empirically (eg flight testing).

Teams shall comply with all rules, regulations, and best practices imposed by the authorities at their chosen test location(s). Departing the launch rail is defined as the first instant in which the launch vehicle becomes free to move about the pitch, yaw, or roll axis. This generally occurs at the instant the last rail guide forward of the vehicle's center of gravity (CG) separates from the launch rail.

Note that ESRA will provide teams with launch rails measuring 17 ft (5.2 m) in length. Teams whose designs anticipate requiring a longer launch rail to achieve stability during launch must provide their own. The requirements for team provided launch rails are defined in Section 10.0 of this document. Section 9.1 of this document describes ESRA provided launch rails.

8.3 ASCENT STABILITY

Launch vehicles shall remain "stable" for the entire ascent. Stable is defined as maintaining a static margin of at least 1.5 to 2 body calibers, regardless of CG movement due to depleting consumables and shifting center of pressure (CP) location due to wave drag effects (which may become significant as low as 0.5 M). Not falling below 2 body calibers will be considered nominal, while falling below 1.5 body calibers will be considered a loss of stability.

8.4 OVER STABILITY

All launch vehicles should avoid becoming "over-stable" during their ascent. A launch vehicle may be considered over-stable with a static margin significantly greater than 2 body calibers (eg greater than 6 body calibers).

9.0 ESRA PROVIDED LAUNCH SUPPORT EQUIPMENT

9.1 ESRA-PROVIDED LAUNCH RAILS

ESRA will provide launch rails that feature 17 ft (5.2 m) long, 1.5" x 1.5" (aka 1515) aluminum guide rails of the 80/20® type. (More details on 80/20® rail profiles may be located on the 80/20® Inc. website: <https://8020.net/>). These rails will accommodate almost any rocket body diameter and fin length. On these rails, the rocket is loaded horizontally on top of the guide rail and then the rail is erected to the required launch elevation. All launch vehicles shall attach to these launch rails via at least two rail guides (lugs/buttons/etc...) which, together, support the vehicle's fully loaded launch weight if suspended horizontally. Once erected, the launch vehicle will be supported vertically by a submerged mechanical stop in the rail - whose position may be adjusted. At the IREC, Competition officials will require teams to lift their launch vehicles by the rail guides and/or demonstrate that the bottom guide can hold the vehicle's weight when vertical before permitting them to proceed with launch preparations.

Note that, unlike in past years, 1.0" x 1.0" (aka 1010) guide rails of the 80/20® type are NO LONGER PROVIDED at the IREC.

9.2 ESRA-PROVIDED LAUNCH CONTROL SYSTEM

ESRA utilizes a Wilson F/X Wireless Launch Control System consisting of one LCU-64x launch control unit and up to four PBU-8w encrypted wireless pad relay boxes (More details on Wilson F/X Digital Launch Control Systems may be found on the Wilson F/X website: www.wilsonfx.com). Each pad relay box may connect and relay a launch command to as many as eight independent launch pads, enabling the launch control unit to command as many as 24 independent launch pads when fully configured. Connection wires are run from the pad relay box to each launch pad. These wires are connected to the motor igniter(s) utilizing alligator clips. Fault tolerance, including propulsion system arming functionality is provided for simple/non-complex, single stage solid propellant rockets by signal encryption and physical arming keys located on the pad relay boxes and launch control unit.

10.0 TEAM-PROVIDED LAUNCH SUPPORT EQUIPMENT

10.1 EQUIPMENT PORTABILITY

If possible/practical, teams should make their launch support equipment man-portable over a short distance (a few hundred feet). Environmental considerations at the launch site permit only limited vehicle use beyond designated roadways, campgrounds, and basecamp areas.

10.2 LAUNCH RAIL ELEVATION

Team provided launch rails shall be set to an appropriate angle set and confirmed by the range safety officer.

10.3 OPERATIONAL RANGE

All team provided launch control systems shall be electronically operated and have a minimum operational range of no less than 1,500 ft from the launch rail. A 2,000 ft operational range is preferred. The maximum operational range is defined as the range at which launch may be commanded reliably.

10.4 FAULT TOLERANCE AND ARMING

All team provided launch control systems shall be at least single fault tolerant by implementing a removable safety interlock (i.e. a jumper or key to be kept in possession of the arming crew during arming) in series with the launch switch. Appendix C of this document provides general guidance on assuring fault tolerance in amateur high power rocketry launch control systems.

10.5 **SAFETY CRITICAL SWITCHES**

All team provided launch control systems shall implement ignition switches of the momentary, normally open (aka "deadman") type so that they will remove the signal when released. Mercury or "pressure roller" switches are not permitted anywhere in team provided launch control systems.

APPENDIX A: ACRONYMS, ABBREVIATIONS, AND TERMS

ACRONYMS & ABBREVIATIONS	
ACS	Attitude Control System
AGL	Above Ground Level
APCP	Ammonium Perchlorate Composite Propellant
CAS	Control Actuator System
CFR	Code of Federal Regulations
CG	Center of Gravity
CONOPS	Concept of Operations
COPV	Composite Overwrapped Pressure Vessel
COTS	Commercial Off-the-Shelf
CP	Center of Pressure
ESRA	Experimental Sounding Rocket Association
FRP	Fiber Reinforced Plastic
IREC	Intercollegiate Rocket Engineering Competition
LOX	Liquid Oxygen
NFPA	National Fire Protection Association
NMSA	New Mexico Spaceport Authority; aka Spaceport America
SAC	Spaceport America Cup
SRAD	Student Researched & Developed
TBD	To Be Determined
TBR	To Be Resolved
TRA	Tripoli Rocketry Association
VLA	Spaceport America Vertical Launch Area
WSMR	White Sands Missile Range
ZSF	Zero Separation Force

TERMS	
Amateur Rocket	14 CFR, Part 1, 1.1 defines an amateur rocket as an unmanned rocket that is "propelled by a motor, or motors having a combined total impulse of 889,600 Newton-seconds (200,000 pound-seconds) or less, and cannot reach an altitude greater than 150 kilometers (93.2 statute miles) above the earth's surface".
Body Caliber	A unit of measure equivalent to the diameter of the launch vehicle airframe in question.
Excessive Damage	Excessive damage is defined as any damage to the point that, if the systems intended consumables were replenished, it could not be launched again safely. Intended Consumables refers to those items which are - within reason - expected to be serviced/replaced following a nominal mission (eg propellants, pressurizing gasses, energetic devices), and may be extended to include replacement of damaged fins specifically designed for easy, rapid replacement.
FAA Class 2 Amateur Rocket	14 CFR, Part 101, Subpart C, 101.22 defines a Class 2 Amateur Rocket (aka High Power Rocket) as "an amateur rocket other than a model rocket that is propelled by a motor or motors having a combined total impulse of 40,960 Newton-seconds (9,208 pound-seconds) or less."
Non-toxic Propellants	For the purposes of the Spaceport America Cup: IREC, the event organizers consider ammonium perchlorate composite propellant (APCP), potassium nitrate and sugar (aka "rocket candy"), nitrous oxide, liquid oxygen (LOX), hydrogen peroxide, kerosene, propane and similar, as non-toxic propellants. Toxic propellants are defined as requiring breathing apparatus, special storage and transport infrastructure, extensive personal protective equipment, etc.

APPENDIX B: SAFETY CRITICAL WIRING GUIDELINES

Introduction

With the aim of supporting recovery reliability and overall safety, this white paper sets out guidelines for all safety critical wiring. This is defined as wiring associated with drogue (or other drag device) deployment, main parachute deployment, and any air-start rocket motors. The wiring techniques described here are optimized for inspectability and ease of field repair. All non-critical wiring is outside the scope of this white paper.

Wiring Guidelines

1. All wire should be stranded, insulated, 22 AWG or larger. Strands should be copper, plated with either silver or tin (entire wire, not just the ends).
 - 1.1. When an off-the-shelf component includes flying leads, those leads may be used unmodified. For example, an E-match may contain solid wire, a battery connector may integrate 26 AWG wire, etc.
 - 1.2. Stranded wire of sizes smaller than 22 AWG may be used only when needed by an off-the-shelf component. For example, if the terminal block on an altimeter is sized to accept 24 AWG wires then that is the size of wire that should be used for that portion of the circuit.
 - 1.3. Wire strands should never be removed in order to allow a wire to fit into a smaller hole or terminal. Use smaller wire for this purpose.
2. Wire should be stripped only with a wire stripping tool of the correct gauge. Any severed strands should be cause for rejection.
 - 2.1. The best wire stripping is achieved with thermal strippers and Teflon/Tefzel wire, however these are not absolutely necessary. PVC-insulated wire is acceptable and may be stripped with thermal strippers (preferred; Digikey part no. PTS-10-ND, \$80, for example) or good quality mechanical strippers (Digikey part no. K503-ND, \$34, for example, also available on Amazon for \$27.88. Other similar strippers on Amazon are “Seatek SA200SK” \$22.25, “Paladin Tools 1116” \$18.20, “Fluke Networks 11230002” \$22.99, “Wiha 44220” \$26.57, though we have not tried these).
 - 2.2. Personnel using a new stripper for the first time should practice on a piece of scrap wire the same gauge and type as will be used. Strip a short length and then strip more insulation from the same wire. If you can now see scratches or nicks in the wire strands from the first strip, something is wrong with either tool or technique.
 - 2.3. Pocket knives and teeth are not recommended
3. Each end of a wire should be terminated in one of the following approved methods, with exceptions in Paragraphs 4 and 5 below:
 - 3.1. Crimped into a crimp terminal (preferred). This includes crimp terminals on multiconductor connectors such as 9-pin D-sub connectors (see table below).
 - 3.2. Screwed into a binding screw terminal (acceptable).
4. Wires should be terminated into a terminal block, only if a piece of off-the-shelf equipment (i.e. an altimeter) has built-in terminal blocks and so there is no other choice. Two-piece terminal blocks must be positively secured together – friction fit is insufficient.
5. Wires should be terminated by soldering, only if a piece of off-the-shelf equipment (i.e. an arming key switch) has built-in solder terminals and so there is no other choice.
 - 5.1. There's nothing wrong with solder, of course. The issue is that the reliability of a solder joint cannot be established by visual inspection alone. There are a number of process parameters (temperature profile,

solder alloy, flux, gold removal, etc.) that must be well controlled to give reliable results and these cannot be inspected post-fact.

6. All crimp operations should be performed with the correct tooling, using crimp terminals sized for the appropriate wire gauge. Where multiple wires are crimped into a single terminal, calculate the effective gauge (for example, two 22 AWG are effectively 19 AWG).
 - 6.1. Crimp tooling should not be improvised from pliers, vices, or other incorrect tools. Crimp features of multitools (Leatherman, Gerber, etc) should not be used.
 - 6.2. Crimp tooling can be expensive (the cheapest one from Digikey is \$262!). You may want to borrow it from a sponsor. The following crimpers are available on Amazon, though we have not tried them ourselves: “Ratcheting Crimper from CML Supply” \$25.33, “S&G Tool Aid 18920” \$75.00, “Astro Pneumatic 9477” \$73.99, “Ancor 701030” \$63.59. Harbor Freight 97420 is only \$9.99—we may buy one just to try it out.
7. Terminals with insulated plastic sleeves (usually colour-coded to indicate barrel size) should not be crimped.
 - 7.1. If a terminal is supplied with an insulated plastic sleeve, it should be removed prior to use. It may be necessary to adjust the crimp tooling to get a tighter squeeze.
 - 7.2. The crimp quality of insulated terminals is difficult to inspect. There is normally no need for insulation when terminals are mounted properly in barrier blocks. If insulation is needed, add clear heat-shrink tubing.
8. When a bare wire is held down by a binding screw terminal the wire should make a 180 degree hook, and strands must be visible exiting the screw head. Only one wire should be permitted per screw. The wire bend should be clockwise, so that it will tighten as the screw is torqued.
9. When ring or spade terminals are held down by binding screw terminals, a maximum of two terminals are allowed per screw.
10. A maximum of three wires should be crimped into a single terminal barrel. Butt-splice terminals are considered to have separate barrels in each end.
11. If two or more wires must be joined, one of the following approved methods should be used:

Note: for the purposes of this white paper, “barrier blocks” have screw terminals between insulating barriers, and often have metal jumpers between screws to allow electrical connections of screws across the block. The screws are usually larger than those in terminal blocks and are easily visible for inspection. The screws are designed to allow the connection of bare wires (turned in a clockwise “J” shape) or ring terminals.

 - 11.1. Crimp a ring terminal onto each wire, and then screw them into a barrier block. Add approved barrier block jumper pieces if many wires must be joined.
 - 11.2. Screw bare wires under binding head screws in a barrier block. Add approved barrier block jumper pieces if many wires must be joined.
 - 11.3. Crimp the wires into an un-insulated butt-splice terminal, and then insulate with clear heat-shrink tubing.
 - 11.4. Any wire-twisting splice method (including wire nuts) is explicitly forbidden. Forget everything you know about household wiring. Houses don't see launch vibration!
12. All insulating tubing (usually heat-shrink) should be transparent.
 - 12.1. This allows inspection of the underlying hardware. It's a good habit to get into.
13. No tape, glue or RTV should be used to insulate or bundle any element of the wire harness.
 - 13.1. If you have followed these guidelines properly there should be no exposed metal in need of insulation.
 - 13.2. Tape (especially PVC electrical tape) is messy and uninspectable
14. The following rules apply to connectors:
 - 14.1. They should use crimp contacts, as soldering has been forbidden.
 - 14.2. They should use a positive locking mechanism to keep the two halves mated under vibration and tension. Friction fit alone is not acceptable.

- 14.3. Plastic connector latches should not be used (such as found on automotive applications), but circular connectors with plastic coupling nuts are acceptable.
- 15. Individual wires should be bundled together to make a harness (factory multi-conductor wiring in a common outer jacket is also acceptable). The safety critical harness should be kept separate from the payload harness (if any). Bundling should be accomplished by:
 - 15.1. A light twist (for mechanical reasons only, no EMC mitigation is intended).
 - 15.2. Short (1 cm) lengths of clear heat-shrink tubing or zip-ties every 5 cm.
 - 15.3. Wire mesh sleeving, provided it allows for inspection of the wiring inside.
- 16. The harness should be supported by plastic P-clamps. It should not be permitted to touch any sharp edge or screw thread.
- 17. All items that are connected by the harness (barrier blocks, sensors, batteries, actuators, switches, etc) should be rigidly fixed to the rocket structure so that they cannot move. Rigid fixing implies attachment with threaded fasteners or a solid glue bond. Cable ties and/or tape are not acceptable examples of rigid fixing.
- 18. No wire should be tight. All wire must have some slack, demonstrated by a curve at its termination.
- 19. Batteries should be connected appropriately:
 - 19.1. 9V transistor batteries should be secured in clips, and connected using proper snap terminals.
 - 19.2. Gel-cell batteries should be secured with clamps, and connected using “faston” crimp terminals.
 - 19.3. Cylindrical batteries (AAA, AA, C, D, etc) should be mounted into commercial holders. The holders should be rigidly secured to the structure, and the batteries should then be strapped into the holders.

Circuit Board Guidelines

All heavy components should be staked. All IC sockets and press-fit contacts should be positively restrained so that they cannot demate under vibration. Provided they are done right, wirewrap, through-hole solder, and surface-mount solder are all acceptable fabrication methods. Solderless breadboard (aka plug-in breadboard) should not be used. Any commercial board for the high-power rocketry market should be considered to be of sufficient quality, provided it is in an undamaged factory state.

Recommended Parts

Here are some recommended components that can be bought from Digikey, Mouser, and Amazon that will help to satisfy the wiring guidelines. These are recommendations only, and you are free to choose other parts and buy from other suppliers. Look up the catalog pages associated with each Digikey or Mouser number to find similar parts of different sizes.

<u>Part</u>	<u>Number</u>	<u>Notes</u>
Wire	Digikey A5855W-100-ND	This is good 22-gauge, tinned, Teflon insulated wire. Cold-flow is a long-term consideration, but shouldn't be a problem for a short lifetime rocket.
Wire	Digikey C2016L-100-ND	22-gauge tinned PVC-insulated wire. Note that the “L” designates the insulation color (other colors are B,R,A,Y,N,W)
Wire	Digikey W120-100-ND Digikey W121-100-ND	2-conductor, 22-gauge 3-conductor, 22-gauge
Wire	Amazon “Tinned marine grade wire”	18-gauge, available in 35-ft or 100-ft rolls
Ring terminals, uninsulated	Digikey A27021-ND (#6 hole)	The Solistrand series is a high quality terminal. Various crimp

		tools are available. You get what you pay for – the expensive ones are very nice, but the basic ones will do in a pinch.
Butt-splice terminal	Digikey A09012-ND	Another Solistrand series terminal
“Faston” terminal	Digikey 298-10011-ND (check size)	These terminals are useful for connecting switches, gel cell batteries, and many automotive devices
9V battery holder, with solder terminals	Digikey 708-1409-ND	Screw this holder to your chassis, and then cable tie the battery in. Note: snap-on 9V battery connectors such as Digikey BS12I-ND are not acceptable.
4 AA battery holder	Digikey 708-1399-ND	This is a nice enclosed battery box for 4 AA cells
P-clamp	Digikey 7624K-ND (check size)	This particular unit is for a 0.25” dia harness. Select the correct size.
Heat-shrink tubing	Digikey A014C-4-ND (check size) Mouser 650-RNF100 (check size)	Material is clear polyolefin with low shrink temperature. Shrink with hot-air gun or oven.
Barrier block (double row)	Digikey CBB206-ND Mouser 538-2140 or 4140 (0.375” pitch), 538-2141 or 4141 (0.438” pitch)	Available in a range of lengths. Can accept ring or spade terminals (preferred), or bare wire (acceptable).
Barrier block jumper	Digikey CBB314-ND	Connect adjacent strips, when many wires need to be connected together
D-sub connectors (9 contact)	Digikey A31886-ND (male shell) Digikey A34104-ND (female shell) Digikey A1679-ND (male pins) Digikey A1680-ND (female pins)	The connectors and contacts are cheap, but the crimp tools are expensive.
D-sub fixing hardware	Digikey MDVS22-ND (screw) Digikey MDVS44-ND (socket)	These kits convert the D-sub friction fit into a proper positive lock.
MIL-C-38999 connectors	Digikey 956-1017-ND (13 pin panel mount receptacle with pins) Digikey 956-1020-ND (13 pin plug with sockets)	These connectors approach the style and quality used on orbital launch vehicles. Extremely robust, but very expensive!

APPENDIX C: FIRE CONTROL SYSTEM DESIGN GUIDELINES

Introduction

The following white paper is written to illustrate safe fire control system design best practices and philosophy to student teams participating in the IREC. When it comes to firing (launch) systems for large amateur rockets, safety is paramount. This is a concept that everyone agrees with but it is apparent that few truly appreciate what constitutes a “safe” firing system. Whether they’ve ever seen it codified or not, most rocketeers understand the basics:

- The control console should be designed such that two deliberate actions are required to fire the system.
- The system should include a power interrupt such that firing current cannot be sent to the firing leads while personnel are at the pad and this interrupt should be under the control of personnel at the pad.

These are good design concepts and if everything is working as it should they result in a perfectly safe firing system. But “everything is working as it should” is a dangerous assumption to make. Control consoles bounce around in the backs of trucks during transport. Cables get stepped on, tripped over, and run over. Switches get sand and grit in them. In other words, components fail. As such, there is one more concept that should be incorporated into the design of a firing system:

The failure of any single component should not compromise the safety of the firing system.

Proper Fire Control System Design Philosophy

Let us examine a firing system that may at first glance appear to be simple, well designed, and safe (Figure 1). If everything is functioning as designed, this is a perfectly safe firing system, but let’s examine the system for compliance with proper safe design practices.

The control console should be designed such that two deliberate actions are required to launch the rocket. Check! There are actually three deliberate actions required at the control console: (1) insert the key, (2) turn the key to arm the system, (3) press the fire button.

The system should include a power interrupt such that ignition current cannot be sent to the firing leads while personnel are at the pad and this interrupt should be under control of personnel at the pad. Check and check! The Firing relay effectively isolates the electric match from the firing power supply (battery) and as the operator at the pad should have the key in his pocket, there is no way that a person at the control console can accidentally fire the rocket.

But all of this assumes that everything in the firing system is working as it should. Are there any single component failures that can cause a compromise in the safety of this system? Yes. In a system that only has five components beyond the firing lines and e-match, three of those components can fail with potentially lethal results.

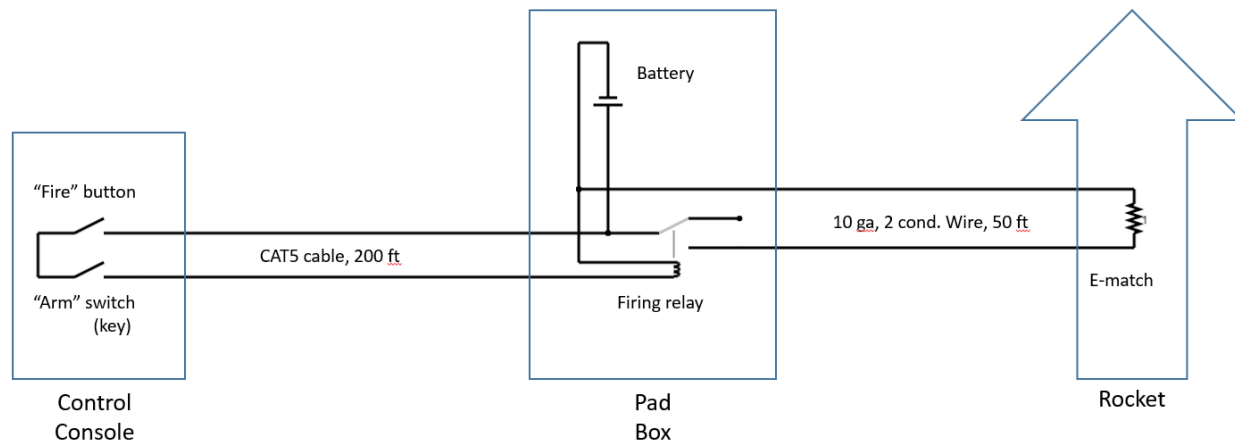

Figure 1: A simple high current fire control system.

Firing Relay. If the firing relay was stuck in the ON position: The rocket would fire the moment it was hooked to the firing lines. This is a serious safety failure with potentially lethal consequences as the rocket would be igniting with pad personnel in immediate proximity.

Arming Switch. If the arm key switch failed in the ON position simply pushing the fire button would result in a fired rocket whether intentional or not. This is particularly concerning as the launch key – intended as a safety measure controlled by pad personnel – becomes utterly meaningless. Assuming all procedures were followed, the launch would go off without a hitch. Regardless, this is a safety failure as only one action (pressing the fire button) would be required at the control console to launch the rocket. Such a button press could easily happen by accident. If personnel at the pad were near the rocket at the time we are again dealing with a potentially lethal outcome

CAT5 Cable. If the CAT5 cable was damaged and had a short in it the firing relay would be closed and the rocket would fire the moment it was hooked to the firing lines. This too is a potentially lethal safety failure.

Notice that all three of these failures could result in the rocket being fired while there are still personnel in immediate proximity to the rocket. A properly designed firing system does not allow single component failures to have such drastic consequences. Fortunately, the system can be fixed with relative ease. Consider the revised system (Figure 2). It has four additional features built into it: (1) A separate battery to power the relay (as opposed to relying on the primary battery at the pad), (2) a flip cover over the fire button, (3) a lamp/buzzer in parallel with the firing leads (to provide a visual/auditory warning in the event that voltage is present at the firing lines), and (4) a switch to short out the firing leads during hookup (pad personnel should turn the shunt switch ON anytime they approach the rocket).

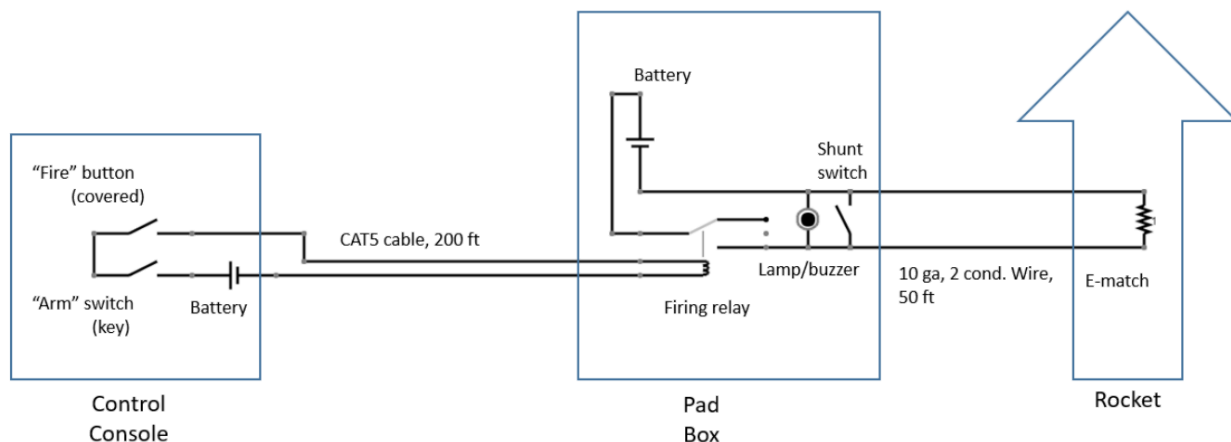

Figure 2: An improved high current fire control system.

In theory, these simple modifications to the previous firing circuit have addressed all identified single point failures in the system. The system has 8 components excluding the firing lines and e-match (part of the rocket itself). Can the failure of any of these components cause an inadvertent firing? That is the question. Let us examine the consequences of the failure of each of these components.

Fire Button. If the fire button fails in the ON position, there are still two deliberate actions at the control console required to fire the rocket. (1) The key must be inserted into the arming switch, and (2) the key must be rotated. The firing will be a bit of a surprise, but it will not result in a safety failure as all personnel should have been cleared by the time possession of the key is transferred to the Firing Officer.

Arm Switch. If the arm switch were to fail in the ON position, there are still two deliberate actions at the control console required to fire the rocket. (1) The cover over the fire button would have to be removed, and (2) the fire button would have to be pushed. This is not an ideal situation as the system would appear to function flawlessly even though it is malfunctioning and the key in the possession of personnel at the launch pad adds nothing to the safety of the overall system. It is for this reason that the shunting switch should be used. Use of the shunting switch means that any firing current would be dumped through the shunting switch rather than the e-match until the pad personnel are clear of the rocket. Thus, personnel at the pad retain a measure of control even in the presence of a malfunctioning arming switch and grossly negligent use of the control console.

Batteries. If either battery (control console or pad box) fails, firing current cannot get to the e-match either because the firing relay does not close or because no firing current is available. No fire means no safety violation.

CAT5 Cable. If the CAT5 cable were to be damaged and shorted, the system would simply not work as current intended to pull in the firing relay would simply travel through the short. No fire means no safety violation.

Firing Relay. If the firing relay fails in the ON position the light/buzzer should alert the pad operator of the failure before he even approaches the pad to hook up the e-match.

Shunt switch, Lamp/Buzzer. These are all supplementary safety devices. They are intended as added layers of safety to protect and/or warn of failures of other system components. Their correct (or incorrect) function cannot cause an inadvertent firing.

Is this a perfect firing system? No. There is always room for improvement. Lighted switches or similar features could be added to provide feedback on the health of all components. Support for firings at multiple launch pads could be included. Support for the fueling of hybrids and/or liquids could be required. A wireless data link could

provide convenient and easy to set up communications at greater ranges. The list of desired features is going to be heavily situation dependent and is more likely to be limited by money than good ideas.

Hopefully the reader is getting the gist: The circuit should be designed such that no single equipment failure can result in the inadvertent firing of the e-match and thus, the rocket motor. Whether or not a particular circuit is applicable to any given scenario is beside the larger point that in the event of any single failure a firing system should always fail safe and never fail in a dangerous manner. No matter how complicated the system may be, it should be analyzed in depth and the failure of any single component should never result in the firing of a rocket during an unsafe range condition. Note that this is the bare minimum requirement; ideally, a firing system can handle multiple failures in a safe manner.

APPENDIX D: AIRSTART IGNITION WIRING DIAGRAM

