



International Rocket Engineering Competition
Design, Test, & Evaluation Guide

Revision: 2024 V1.1.3
October 22, 2024

*This work is licensed under a [Creative Commons 4.0 International License](https://creativecommons.org/licenses/by/4.0/)
Attribute to the Experimental Sounding Rocket Association
The electronic version is the official, approved document.
Verify this is the correct version before use.*

This page intentionally left blank.

Contents

1.0 Introduction	6
1.1 Background	6
1.2 Purpose and Scope	6
1.3 Convention and Notation	7
1.4 Flight Status	7
1.5 Launch Vehicle versus Payload	7
1.6 Revisions	7
2.0 Reference Documentation	9
3.0 High Power Certified Flyer of Record	10
3.1 Tripoli Flight Requirements for Solid and Hybrid Categories	10
3.2 team Members	10
4.0 GPS Tracking Requirements for all IREC Rocket Flights	11
4.1 Tracking Solutions	11
4.2 Frequency Management	11
4.3 Multiple GPS trackers	12
4.4 SRAD GPS Tracking systems	12
4.5 FCC Amateur radio Licensing	12
4.6 GPS Tracking Solution Safety Inspections	13
4.7 Recovery Team Training and recovery GPS System Review at Team Registration	13
4.8 MCC Coordination During Recovery	13
5.0 Propulsion systems	14
5.1 Motor Categories	14
5.2 Propulsion Types	14
5.3 Igniters	15
5.4 Non-Toxic Propellants	15
5.5 Sugar Motor Propellants	15
5.6 Allowable materials for Case Components for SRAD Motors	15
5.7 Propulsion System Safing and Arming	15
5.8 Ground-start Ignition Circuit Arming	16
5.9 Air-start/Staged Ignition Circuit Arming	16
5.10 Propellant Offloading After Launch Abort	16
5.11 Air-Start/Staged Ignition Circuit Electronics	16
5.12 Air-Start/Staged or Cluster Thrust-to-Weight Requirements	16
5.13 Air-Start/Staged Flight Computer Requirements	16
5.14 Air-Start/Staged Flights – Arming Procedures	17
5.15 Air-Start/Staged Flights – Additional Information Requirements	17
5.16 SRAD Propulsion System Testing	17
5.17 Minimum thrust-to-Weight Ratio	18

5.18	SRAD Hybrid/Liquid Pad Operations Design Requirements	18
6.0	Recovery Systems and Avionics	20
6.1	Dual-Event Parachute and Parafoil Recovery	20
6.2	Recovery Area	20
6.3	Initial Deployment Event	21
6.4	Main Deployment Event	21
6.5	Ejection Gas Protection	21
6.6	Parachute Swivel Links	21
6.7	Parachute Coloration and markings	21
6.8	Non-parachute/Parafoil Recovery Systems	21
6.9	Redundant Electronics	21
6.10	Redundant COTS Recovery Electronics	22
6.11	SRAD Recovery Electronics	22
6.12	Safety Critical Wiring for Recovery Systems and Air-Start Motors	22
6.13	Recovery system Testing	23
6.14	Stored-energy Devices – Energetic Device Safing and Arming	24
6.15	Arming Devices	24
6.16	Arming Device Verification	25
6.17	SRAD Pressure Vessels	25
6.18	Batteries contained in the rocket	26
6.19	Transmitters Contained in the Rocket	26
7.0	Active Flight Control Systems	27
7.1	Restricted Control Functionality	27
7.2	Unnecessary for Stable Flight	27
7.3	Designed to fail Safe	27
7.4	Boost Phase Dormancy	27
7.5	Active Flight Control System Electronics	27
7.6	Active Flight Control System Energetics	28
8.0	Airframe structures	29
8.1	Adequate Venting	29
8.2	Overall Structural Integrity	29
8.3	Material Prohibitions	29
8.4	Load Bearing Eye Bolts And U-Bolts	29
8.5	Joints Implementing Coupling Tubes	29
8.6	Rail Buttons	30
8.7	Identifying Markings	30
8.8	Other Markings	30
9.0	Payload	32
9.1	Payload Recovery	32

9.2	Payload Recovery System Electronics and Safety Critical Wiring	32
9.3	Payload Recovery System Testing	32
9.4	Payload Energetic Devices	32
9.5	Payload Identifying Markings	32
10.0	Launch and Ascent Trajectory Requirements	33
10.1	Launch Azimuth and Elevation	33
10.2	Launch Stability	33
10.3	Ascent Stability	33
10.4	Over-Stability	33
11.0	ESRA Provided Launch Support Equipment	34
11.1	ESRA-provided Launch Rails	34
11.2	ESRA-Provided Launch Control System	34
11.3	Team-Provided Launch Support Equipment	34
11.4	Operational Range	35
11.5	Fault Tolerance and Arming	35
11.6	Safety Critical Switches	35
	Appendix A: Acronyms, Abbreviations, and Terms	36
	Appendix B: Safety Critical Wiring Guidelines	38
	Appendix C: Fire Control System Design Guidelines	45
	Appendix D: Airstart ignition wiring diagram	50
	Appendix E: ESRA & Tripoli Rocket Association Partnership	51
	Appendix F: Example Booster Airframe Markings	54
	Appendix G: Standard Weather Conditions	55
	Appendix H: Document Revisions	56

1.0 INTRODUCTION

The Experimental Sounding Rocket Association (ESRA) hosts and supports the 2025 International Rocketry Engineering Competition (IREC), a week-long series of events which will set the background and provide structure for the world's largest university rocket engineering competition. This new host event continues the IREC legacy of inspiring student design teams from across the country and around the world.

1.1 BACKGROUND

The smoke and fire, noise, high speeds, and sleek aerodynamics of rocketry encourage students to pursue science, technology, and mathematics-based careers. They have Rocket Fever!, and competition motivates them to extend themselves beyond the classroom to design and build the rockets themselves. These students also learn to work as a team, solving real world problems under the same pressures they'll experience in their future careers.

ESRA held the first annual IREC in 2006. The competition achieved international status in 2011 when Canadian and Brazilian universities arrived. These schools have since been joined by others from every continent except Antarctica. The competition has increased in size every year since 2013, becoming the largest known collegiate level rocket engineering competition in the world. Attendance in 2016 included as many as 600 participants – including faculty, family, and friends of students from over 50 colleges and universities. The next year marked the start of a new era with the inaugural Spaceport America Cup. Over 1,100 students and representatives from 22 industry partners participated in an academic conference, rocket and payload engineering competitions, and non-competing demonstration flight tests. IREC continues to grow with nearly 200 teams applying for admission to the competition in 2023 with 121 teams and over 2,000 students from around the world making the trip to Spaceport America in June of 2023 for the competition.

1.2 PURPOSE AND SCOPE

1.2.1 This document defines the minimum design, test, and evaluation criteria the event organizers expect teams to meet before launching at the IREC. The event organizers use these criteria to promote flight safety. Departures from the guidance this document provides may negatively impact an offending team's score and flight status, depending on the degree of severity. The foundational, qualifying criteria for the IREC are contained in the IREC Rules & Requirement document.

1.2.2 This document builds upon:

1.2.2.1 Tripoli Rocketry Association (TRA) Unified Safety Code (USC)

1.2.2.2 National Fire Protection Association (NFPA) Code for High Power Rocketry (NFPA 1127). While NFPA 1127, Section 1.3.3 exempts colleges and universities from its contents, these documents remain excellent supplemental resources for student researchers to learn more about best practices adopted by the amateur high-power rocketry community.

1.2.2.3 ESRA's observations on student launch initiatives.

1.2.2.4 Feedback received from student teams.

1.2.3 If any IREC team is unclear about competition rules and/or requirements, or has a situation not specifically addressed by the rules, they should contact ESRA by posting a message in the "Rules and DTEG Questions" forum on HeroX. Teams

are encouraged to ask about both detailed requirement interpretation and the spirit and intent of the rules and DTEG.

1.3 CONVENTION AND NOTATION

The following definitions differentiate between requirements and other statements. The degree to which a team satisfies the spirit and intent of these statements will guide the competition officials' decisions on a project's flight status and overall score at the IREC.

Shall: This is the only verb used to denote mandatory requirements. Failure to satisfy the spirit and intent of a mandatory requirement will always affect a project's score and flight status.

May: This verb signifies that teams are allowed, but not required, to exercise the associated action.

Should: This verb is used for stating non-mandatory goals. Failure to satisfy the spirit and intent of a non-mandatory goal may affect a project's score and flight status, depending on design implementation and the team's ability to provide thorough documentary evidence of their due diligence on-demand.

Will: This verb is used for stating facts and declarations of purpose. The authors use these statements to clarify the spirit and intent of requirements and goals.

1.4 FLIGHT STATUS

Flight status refers to the granting of permission to attempt flight, and the provisions under which that permission remains valid. A project's flight status may be either nominal, provisional, or denied.

Nominal: A project assigned nominal flight status meets or exceeds the minimum expectations of this document and reveals no obvious flight safety concerns during flight safety review at the IREC.

Provisional: A project assigned provisional flight status generally meets the minimum expectations of this document but reveals flight safety concerns during flight safety review at the IREC which may be mitigated by field modification or by adjusting launch environment constraints. Launch may occur only when the prescribed provisions are met.

Denied: Competition officials reserve the right to deny flight status to any project which fails to meet the minimum expectations of this document or reveals un-mitigatable flight safety concerns during flight safety review at the IREC.

1.5 LAUNCH VEHICLE VERSUS PAYLOAD

An effort is made throughout this document to differentiate between launch vehicle and payload associated systems. Unless otherwise stated, requirements referring only to the launch vehicle do not apply to payloads and vice versa.

1.6 REVISIONS

The IREC DTEG may require revision from one competition to the next, based on the lessons learned by both host organizations and the participants.

1.6.1 Major revisions will be accomplished by complete document reissue.

- 1.6.2 “Real world events” may require smaller revisions to this document in the months leading up to a competition.
- 1.6.3 Revisions will be reflected in updates to the document’s effective date.
- 1.6.4 The authority to approve and issue revised versions of this document rests with ESRA.

2.0 REFERENCE DOCUMENTATION

The following documents include standards, guidelines, schedules, or required standard forms. The documents listed in this section are either applicable to the extent specified in this document or contain reference information useful in the application of this document.

DOCUMENT	FILE LOCATION
IREC Rules & Requirements Document	http://www.soundingrocket.org/sa-cup-documents-forms.html
IREC Integrated Master Schedule Document	http://www.soundingrocket.org/sa-cup-documents-forms.html
IREC Range Standard Operating Procedures	http://www.soundingrocket.org/sa-cup-documents-forms.html
IREC Entry Form & Progress Report	http://www.soundingrocket.org/sa-cup-documents-forms.html
TRA Unified Safety Code	https://www.tripoli.org/content.aspx?page_id=22&club_id=795696&module_id=520420
NFPA 1127: Code for High-Power Rocketry	https://www.nfpa.org/codes-and-standards/all-codes-and-standards/list-of-codes-and-standards/detail?code=1127
14 CFR, Part 1, 1.1 General Definitions	http://www.ecfr.gov/cgi-bin/text-idx?SID=795aaa37494b6c99641135267af8161e&mc=true&node=se14.1.1_11&rgn=div8
14 CFR, Part 101, Subpart C, 101.22 Definitions	http://www.ecfr.gov/cgi-bin/text-idx?SID=795aaa37494b6c99641135267af8161e&mc=true&node=se14.2.101_122&rgn=div8
47 CFR, Part 97, Amateur Radio Service	https://www.ecfr.gov/current/title-47/chapter-I/subchapter-D/part-97

3.0 HIGH POWER CERTIFIED FLYER OF RECORD

3.1 TRIPOLI FLIGHT REQUIREMENTS FOR SOLID AND HYBRID CATEGORIES

- 3.1.1 Every team shall engage a TRA-certified Level 3 (L3) Flyer of Record (FoR). Any one of the following options shall satisfy this FoR requirement.
 - 3.1.1.1 Recruit a mentor with significant rocketry experience to work closely with the team and then attend the Competition as FoR. Student teams should pay the travel expenses of their FoR/Mentor to attend the event.
 - 3.1.1.2 Include as a member of the team a TRA-certified L3 student. In this case, the student L3 member shall be the Flyer of Record.
 - 3.1.1.3 International teams who have no access to local or regional Tripoli prefectures should first attempt a search using social media, forums and other web-based sites (Facebook, Discord, *etc.*) to find a suitable Flyer of Record. If that search does not find a FoR, teams should contact the Tripoli Rocketry Association's Outreach Committee for assistance. (<https://www.tripoli.org/outreach>)
- 3.1.2 The Flyer of Record shall be present for:
 - 3.1.2.1 Fight Readiness Review (Convention Center)
 - 3.1.2.2 Final RSO Check (immediately prior to entering queue)
 - 3.1.2.3 launch preparation, and
 - 3.1.2.4 pad loading.
- 3.1.3 It is recommended that motors or energetic materials only be possessed or handled by TRA members with appropriate high power rocketry certification.

3.2 TEAM MEMBERS

- 3.2.1 Teams flying in the Solid or Hybrid categories shall meet all TRA launch safety requirements as codified in the then-current Tripoli Rocketry Association Unified Safety Code.
- 3.2.2 All team members who will be on onsite at the launch site shall hold a current TRA membership.
 - 3.2.2.1 TRA Student membership shall satisfy requirement 3.2.2
- 3.2.3 A maximum of 5 student team members may be on the pad loading team.
 - 3.2.3.1 The team Mentor may be present at the pads and does not count in the team limit in 3.2.3.
 - 3.2.3.2 The FoR shall be present at the pads and does not count in the team limit in 3.2.3
- 3.2.4 The recovery team shall contain a minimum of 2 and a maximum of 4 team members per 100 lbs. of recovery equipment, including the dry weight of the rocket.
 - 3.2.4.1 The Mentor and/or FoR may accompany the recovery team and are not include in the team member count.

4.0 GPS TRACKING REQUIREMENTS FOR ALL IREC ROCKET FLIGHTS

4.1 TRACKING SOLUTIONS

4.1.1 All rockets shall include a GPS tracking solution.

4.1.2 Tracking solutions shall be powered independently of any flight computer.

4.1.3 IREC Recommended COTS GPS Trackers:

Vendor	Product		Website
Entacore Off We Go Rocketry (USA)	AIM XTRA/BASE	900 MHz	http://entacore.com/electronics/aimxtra https://offwegorocketry.com/
Altus Metrum	TeleGPS, TeleMega, etc.	70 cm APRS	https://altusmetrum.org/
Big Red Bee	Beeline GPS, BRB900	70 cm APRS 900 Mhz	http://www.bigredbee.com/
Featherweight	Featherweight GPS	900 MHz	https://www.featherweightaltimeters.com/featherweight-gps-tracker.html
Multitronix	Kate-3	900 MHz	https://www.multitronix.com/

4.1.4 GPS Tracker Frequency Options

4.1.4.1 144 MHz (2 m) – Requires US Amateur Radio license or operating authority.

4.1.4.2 440 MHz (70 cm) – Requires US Amateur Radio license or operating authority.

4.1.4.3 900 MHz (33 cm) – Does not require an Amateur Radio license.

4.1.4.4 MCC has a very limited number of 900 MHz receivers which may result in launch delays.

4.2 FREQUENCY MANAGEMENT

4.2.1 The Mission Control Center (MCC) will be responsible for frequency management during the IREC.

4.2.2 All teams will receive an initial frequency assignment from MCC prior to arriving in the host city.

4.2.3 Teams shall not power any transmitting electronics while in the pit area

4.2.4 The MCC will maintain the team assigned frequency database.

4.2.5 Teams shall have the ability to quickly change frequencies on their transmitting and receiving equipment.

4.2.6 Teams shall not transmit on a frequency that is not assigned to them.

4.2.7 Teams shall minimize usage of tracking transmitters during range operations to only testing and actual flight operations. All tracking transmitters shall be powered off when not in use.

- 4.2.8 Trackers that allow custom names to be assigned to the tracker shall include the team number as the first characters of the tracker's name. (e.g., Featherweight tracker) preceded by "<T" and followed by ">", e.g., Team 999's tracker name would be "<T999T>" (without the quotes)¹.
- 4.2.9 Frequency Hopping/Spread Spectrum tracking transmitters are permitted subject to the following:
 - 4.2.9.1 The team shall coordinate with MCC prior to arrival in the host city.
 - 4.2.9.2 The team shall provide to MCC a receiver and all necessary additional hardware and software required to interface with MCC equipment and decode data.
- 4.2.10 Should a tracking frequency conflict between teams waiting in the queue or at the pads manifest, it shall be the responsibility of the affected teams to resolve the conflict:
 - 4.2.10.1 One team changing their tracking system to a different (unused) frequency, or
 - 4.2.10.2 One team delaying their launch to a subsequent salvo.

4.3 MULTIPLE GPS TRACKERS

- 4.3.1 Student teams may have multiple GPS Tracking solutions within their rocket. All solutions shall meet the following requirements.
 - 4.3.1.1 All transmitting devices on the rocket shall be documented in progress reports.
 - 4.3.1.2 Frequencies for all devices shall be coordinated with MCC.
 - 4.3.1.3 It is recommended that multiple GPS trackers not be the same product.

4.4 SRAD GPS TRACKING SYSTEMS

- 4.4.1 SRAD GPS solutions are approved subject to the following:
 - 4.4.1.1 Additional documentation detailing the design, fabrication, operation, and testing of SRAD GPS tracking systems shall be included in progress reports.
 - 4.4.1.2 SRAD GPS tracking systems shall be able to change frequency easily and rapidly as needed, even on the range.
 - 4.4.1.3 Transmissions on the same frequency from different systems, e.g., stages, (transmitters) shall be shifted using GPS time slotting.
 - 4.4.1.4 Proof of successful ground testing shall be shown during the third progress report.
- 4.4.2 APRS protocol is recommended for SRAD GPS Tracking, see <http://www.aprs.org/doc/APRS101.PDF>.
- 4.4.3 It is recommended to flight-test SRAD GPS systems.
- 4.4.4 SRAD GPS Tracking Systems will not be used for official Post Flight Data Recovery altitude determination.

4.5 FCC AMATEUR RADIO LICENSING

- 4.5.1 All student teams are recommended to get an Amateur Radio Operator's license for their country.
- 4.5.2 70 cm and 2 m APRS GPS Tracking solutions require a minimum of the control operator to be licensed at the Technician level or higher.

¹ This is to aid in automatic parsing.

- 4.5.3 The control operator's call sign shall be used by the transmitter.
- 4.5.4 The control operator's call sign and team number shall be registered with MCC prior to final safety inspection.
- 4.5.5 Teams utilizing Amateur Radio frequencies and based outside of the US shall secure US operating authority² or use a solution transmitting at 900 MHz.
- 4.5.6 International teams shall bring documentation in English (translated if required) of their US operating authority.

4.6 GPS TRACKING SOLUTION SAFETY INSPECTIONS

- 4.6.1 IREC personnel at the pads shall verify at least one of the following:
 - 4.6.1.1 The teams are able to communicate with their receiving station and confirm that GPS signals are acquired and functioning properly.
 - 4.6.1.2 MCC is receiving GPS telemetry successfully.
- 4.6.2 Teams will not be allowed to delay launch operations because of GPS inoperability.
- 4.6.3 Teams which cannot confirm a GPS Tracking signal either through their team receiver(s) or through the MCC shall not be allowed to launch.

4.7 RECOVERY TEAM TRAINING AND RECOVERY GPS SYSTEM REVIEW AT TEAM REGISTRATION

- 4.7.1 Prior to arrival in the host city on Monday of the week of the IREC, all members of the recovery team shall complete video training on utilization of the recovery backpack systems
- 4.7.2 During the check-in process in Las Cruces, recovery teams shall verify completion of the training on utilization of the recovery backpack systems.

4.8 MCC COORDINATION DURING RECOVERY

- 4.8.1 Teams shall acquire recovery information for their rocket from the MCC recovery kiosk.
- 4.8.2 Teams attempting to recover their rocket who are unable to determine its location shall contact the MCC via their recovery backpack radio.
- 4.8.3 Teams will provide their Team Identification Number to MCC which will then provide the most recent coordinates received.

² This is most commonly accomplished via reciprocal licensing agreements.

5.0 PROPULSION SYSTEMS

5.1 MOTOR CATEGORIES

5.1.1 COTS Motors

5.1.1.1 A Commercial Off The Shelf (COTS) motor is defined as a motor which has been certified by the Canadian Association of Rocketry, Tripoli, or NAR, and appears on the then current combined Certified Rocket Motors List.

5.1.1.2 A list of all approved motors may be found on the NAR website:
<https://www.nar.org/SandT/pdf/CombinedMotorsByImpulse.pdf>

5.1.2 SRAD Motors

5.1.2.1 Student Research and Developed Motors (SRAD) are defined as

5.1.2.1.1 Any motor built in part or whole by students.

5.1.2.1.2 Any COTS solid motors modified in such a way as to conceivably affect operation or performance of the motor.³

5.1.2.1.3 Any motor utilizing COTS fuel grains in a motor case or configuration not specified by the manufacturer.

5.1.2.2 SRAD motors shall be static fired, and the propellant characterized prior to the final progress report.

5.1.2.3 Static fire test results and propellant characterization data shall be presented during the final progress report.

5.1.2.4 No second party motors (*e.g.*, not built by the team) shall be permitted.

5.2 PROPULSION TYPES

5.2.1 Solid Motor

5.2.1.1 Any motor utilizing exclusively a solid propellant.

5.2.1.2 Solid propellants shall consist of non-toxic ingredients as defined in Section 5.5.

5.2.1.3 All SRAD solid motors shall be static fired, well characterized and tested per section 5.17.

5.2.1.4 All SRAD solid motors shall comply with the TRA Unified Safety code.

5.2.2 Hybrid Motor

5.2.2.1 Any motor utilizing a combination of solid and liquid or gaseous propellants.

5.2.2.2 Hybrid propellants must be non-toxic as defined in Section 5.4 and comply with the TRA Unified Safety code.

5.2.2.3 Nitrous oxide is the only allowable oxidizer.

5.2.3 Liquid Engine

5.2.3.1 A liquid engine is an engine designed with stored fuel and stored oxidizer in the liquid state.

5.2.3.2 All liquid propellants must be non-toxic as defined in Section 5.3.

5.2.3.3 All liquid engines shall be static fired, well characterized, and tested as per section 5.17.

³ For example, modification of the forward closure of a motor to support head end ignition would result in the motor being classified as SRAD.

5.3 IGNITERS

- 5.3.1 Teams shall supply the appropriate means of ignition for their motor.
- 5.3.2 COTS motors shall be started using the igniter supplied by the manufacturer.
- 5.3.3 SRAD motors may be started using either a COTS igniter or a SRAD igniter.
 - 5.3.3.1 Team using an SRAD igniter shall demonstrate the effectiveness of the igniter in starting their motor prior to arriving in the host city.
- 5.3.4 COTS igniters shall not be modified nor enhanced.

5.4 NON-TOXIC PROPELLANTS

- 5.4.1 Launch vehicles entered in the IREC shall use non-toxic propellants.
- 5.4.2 Ammonium perchlorate composite propellant (APCP), potassium nitrate and sugar (aka rocket candy), nitrous oxide, liquid oxygen (LOX), kerosene, propane, alcohol, and similar substances, are considered non-toxic.
- 5.4.3 Toxic propellants are defined as those requiring breathing apparatus, unique storage and transport infrastructure, or extensive personal protective equipment (PPE).

5.5 SUGAR MOTOR PROPELLANTS

- 5.5.1 Sugar propellants shall use potassium nitrate as oxidizer.
- 5.5.2 The following sugars or sugar alcohols are allowable as fuel.
 - 5.5.2.1 Dextrose
 - 5.5.2.2 Erythritol
 - 5.5.2.3 Sorbitol
- 5.5.3 Other chemicals may be used if the fuel includes more than 50% by weight of the sugars or sugar alcohols listed in 5.4.2.

5.6 ALLOWABLE MATERIALS FOR CASE COMPONENTS FOR SRAD MOTORS

- 5.6.1 Metallic cases shall be made of non-ferrous ductile metals such as 6061 aluminum alloy.
- 5.6.2 Non-metallic cases shall not be made of brittle materials which may rupture into sharp shards, such as PVC or other low-temperature polymers.
- 5.6.3 Forward closures shall not be made of ferrous materials.
- 5.6.4 Minor components such as snap rings, nozzle washers, rear closures, and seal disks may be made of ferrous metals.
- 5.6.5 Nozzles for Sugar Motors may be made of steel as long as the throat of the nozzle is recessed within the case.
- 5.6.6 Combustion chambers for hybrid motors shall not be made from any alloy of steel.

5.7 PROPULSION SYSTEM SAFING AND ARMING

- 5.7.1 A propulsion system shall be deemed armed if only one action (*e.g.*, an ignition signal) must occur for the propellant(s) to ignite.
- 5.7.2 The “arming action” is any action enabling an ignition signal to ignite the propellant(s).
- 5.7.3 The IREC provided launch control system described in Section 11.2 will be used for all solid and 2-stage launches.

5.7.4 Hybrid or liquid teams shall provide launch control systems that ensure their rocket is properly made safe, *i.e.*, not armed.

5.7.4.1 A software-based control system that automatically cycles through an “arm function” and an “ignition function” shall include a manual interrupt capability between the “arm” and “ignition” functions.

5.7.4.2 Additional requirements for team-provided launch control systems are defined in Section 11.3 of this document.

5.8 GROUND-START IGNITION CIRCUIT ARMING

5.8.1 All personnel shall be at least 15 m (50 ft) away from the launch vehicle prior to ground-started propulsion system ignition circuits/sequences being armed.

5.8.2 The IREC provided launch control system satisfies this requirement.

5.9 AIR-START/STAGED IGNITION CIRCUIT ARMING

5.9.1 All upper-stage (*i.e.*, air-starts) propulsion systems shall be designed to:

5.9.1.1 prevent motor ignition during arming on the ground,

5.9.1.2 inhibit motor ignition in the event of a non-nominal flight as defined in 5.15.

5.9.1.3 provide the capability of being disarmed in the event the rocket is not launched.

5.10 PROPELLANT OFFLOADING AFTER LAUNCH ABORT

5.10.1 Hybrid and liquid propulsion systems shall implement a means for remotely controlled venting or offloading of all liquid and gaseous propellants.

5.10.2 Normally open purge valves shall be used.

5.11 AIR-START/STAGED IGNITION CIRCUIT ELECTRONICS

5.11.1 All upper-stage ignition systems shall comply with the same requirements for Safety Critical Wiring as recovery systems as defined in 6.12.

5.12 AIR-START/STAGED OR CLUSTER THRUST-TO-WEIGHT REQUIREMENTS

5.12.1 Staged flights shall have a minimum thrust-to-weight ratio of 8 at launch.

5.12.2 The sustainer shall have a minimum thrust-to-weight ratio of 3.

5.12.3 Clustered rockets shall have a minimum thrust-to-weight ratio of 6 on any single motor that is ignited on the pad.

5.13 AIR-START/STAGED FLIGHT COMPUTER REQUIREMENTS

5.13.1 Ignition of air-start motors shall be accomplished using a COTS flight computer configured to inhibit ignition of the air-start motor(s) unless all the following conditions have been met:

5.13.1.1 Booster burnout has been detected,

5.13.1.2 The rocket has reached an altitude of at least 70% of the simulated altitude at the time when initiator firing is desired,

5.13.1.3 The sustainer flight angle is within 20° of vertical.

5.13.2 The flight computer shall be configured to prevent the air-start motor from firing at a later time if the altitude threshold was not achieved.

- 5.13.3 Currently available flight computers that have this capability include, but are not limited to:
 - 5.13.3.1 Featherweight Blue Raven
 - 5.13.3.2 Aim Xtra
 - 5.13.3.3 Multitronix Kate
 - 5.13.3.4 Altus Metrum Telemega and EasyMega
 - 5.13.3.5 MARSAs Systems Marsa33 and Marsa54 flight computers with Tilt Module & Interface
- 5.13.4 SRAD flight computers shall not be used for the purpose of igniting air-start motors.
- 5.13.5 Simple timers shall not be used unless in combination with altitude and tilt lockout.

5.14 AIR-START/STAGED FLIGHTS – ARMING PROCEDURES

- 5.14.1 All projects shall include the capability of preventing air-start motor ignition on the ground.
- 5.14.2 All projects shall include a provision to open the circuit between the flight computer and the motor igniter prior to and during power-up of the flight computer.
- 5.14.3 Shunts are recommended but are not required. Examples of recommended switch designs are provided in Appendix D.
- 5.14.4 Flight computers shall not be armed until the rocket is in a vertical position.
- 5.14.5 The electronics configuration shall be designed such that the provision used to open the circuit to the igniter can be used to safe the igniter if the rocket is not launched.

5.15 AIR-START/STAGED FLIGHTS – ADDITIONAL INFORMATION REQUIREMENTS

- 5.15.1 Teams shall provide additional information in the second progress report specifically related to air-start/staged flights.
- 5.15.2 Updated information, including a response to ESRA comments as applicable, shall be included in the third progress report and final report.
- 5.15.3 The required information includes:
 - 5.15.3.1 Schematic diagram of the electronics configuration to be used for air-start motor ignition and recovery.
 - 5.15.3.2 A graph illustrating flight simulation profile, to include altitude, velocity, and acceleration as a function of time to the expected apogee time.
 - 5.15.3.3 An explanation of the strategy for the flight based on the above flight profile (*i.e.*, what is the rationale behind the selection of staging times, coast times, *etc.*)
 - 5.15.3.4 A description of the specific procedures that will be used to prevent air-start motor ignition on the ground.
 - 5.15.3.5 A description of the specific procedures that will be used to inhibit air-start motor ignition in the event of a non-nominal flight.
 - 5.15.3.6 Drawing & description of the interstage coupler.

5.16 SRAD PROPULSION SYSTEM TESTING

- 5.16.1 Teams shall comply with all rules, regulations, and best practices imposed by the authorities at their chosen test location(s).

- 5.16.2 Teams shall complete required testing of SRAD and modified COTS propulsion systems by the third progress report and final report. Teams unable to make this deadline may switch to COTS propulsion.
- 5.16.3 Combustion Chamber Pressure Testing
 - 5.16.3.1 SRAD and modified COTS propulsion system combustion chambers shall be designed and tested according to the SRAD pressure vessel requirements defined in Section 6.2 of this document.
 - 5.16.3.2 Combustion chambers are exempted from the requirement for a relief device.
- 5.16.4 Hybrid and Liquid Propulsion System Tanking Testing
 - 5.16.4.1 SRAD and modified COTS propulsion systems using liquid or hybrid propellant(s) shall successfully complete a propellant loading and off-loading test in “launch-configuration”.
 - 5.16.4.2 This test may be conducted using either actual propellant(s) or suitable proxy fluids.
 - 5.16.4.3 The loading and off-loading test shall demonstrate meeting the fill to fire time and detanking time requirements of 5.19.
 - 5.16.4.4 Links to videos and testing data shall be included with, or linked to, in the third progress report and final report.
- 5.16.5 Static Hot-Fire Testing
 - 5.16.5.1 SRAD propulsion systems shall successfully complete an instrumented (chamber pressure and thrust), full scale (including system working time) static hot-fire test prior to the IREC.
 - 5.16.5.2 SRAD Solid teams shall provide a BurnSim or openMotor file of their intended motor.
 - 5.16.5.3 SRAD Solid teams shall provide static test data including at least a graph of the pressure and thrust versus time.
 - 5.16.5.4 SRAD static test results shall be provided in the Comma Separated Values (CSV) file format and include Time (sec), Pressure (pascals) and Thrust (newtons) data.
 - 5.16.5.5 Video of successful testing shall be included with, or linked to, in the third progress report and final report.
 - 5.16.5.6 All SRAD motors shall be designed and manufactured by the team.
 - 5.16.5.7 The flight motor shall represent the static test motor in all respects.
 - 5.16.5.8 Any changes to the SRAD flight motor shall be tested and resubmitted.

5.17 MINIMUM THRUST-TO-WEIGHT RATIO

- 5.17.1 Thrust-to-weight ratio shall be calculated based on the average thrust of the motor during the first 1 second of operation divided by the takeoff weight of the rocket (launch vehicle plus payload plus motor).
- 5.17.2 Except as noted in section 5.12, the minimum thrust-to-weight ratio for all competition launches shall be 5:1.

5.18 SRAD HYBRID/LIQUID PAD OPERATIONS DESIGN REQUIREMENTS

- 5.18.1 Fill to fire time shall be ≤ 30 minutes. The filling time is defined as the time from filling start to launch ignition.

- 5.18.2 Pad managers may, using their discretion, permit an additional 15 minutes of fill time.
- 5.18.3 Rockets shall vent/detank in ≤ 30 minutes, including in fault and failsafe conditions.
- 5.18.4 Rockets shall be able to hold fully filled for ≥ 10 minutes before launching.
- 5.18.5 Teams will be told to abort if they do not meet these times.

6.0 RECOVERY SYSTEMS AND AVIONICS

6.1 DUAL-EVENT PARACHUTE AND PARAFOIL RECOVERY

- 6.1.1 Each independently recovered launch vehicle body anticipated to reach an apogee above 457 m (1,500 ft) above ground level (AGL) shall follow a “dual-event” recovery operations concept (CONOPS) defined to include the following:
 - 6.1.1.1 A drogue deployment event of a drogue parachute (or a reefed main parachute) at or near apogee.
 - 6.1.1.2 A main deployment event of a main parachute, or unreefing of a main parachute, at a much lower altitude.
- 6.1.2 Independently recovered bodies (payloads) whose apogee is not anticipated to exceed 1,500 ft (457 m) AGL are exempted from dual deployment and may feature only a single/main deployment event.
- 6.1.3 Boosters from 2-stage rockets are exempted from dual deployment and may feature only a single/main deployment event.
- 6.1.4 A single commercially available release device appropriately rated for large parachutes, *e.g.*, Tinder Rocketry Tender Descender L1, L2, L3, and TD-2, the Rattworks AARD, *etc.*, are permitted subject to the following:
 - 6.1.4.1 Dual initiators shall be used.
 - 6.1.4.2 Redundant energetics (powder charges) are not required.
 - 6.1.4.3 Initiators shall be activated by independent flight computers.
 - 6.1.4.4 The device shall be successfully ground tested under a load approximating the load anticipated during flight.
 - 6.1.4.5 The Jolly Logic Chute Release (JLCR) is not permitted for any recovery purposes.
- 6.1.5 Commercially available line/cable cutters, *e.g.*, Tinder Rocketry Piranha and Mako, Archetype Cable Cutter, *etc.*, are permitted subject to the following.
 - 6.1.5.1 Redundant devices shall be used.
 - 6.1.5.2 The use of dual initiators in a single device does not satisfy 6.1.5.1.
- 6.1.6 SRAD release devices and line/cable cutter devices are permitted subject to the following:
 - 6.1.6.1 Redundant devices shall be used.
 - 6.1.6.2 Activation of redundant devices shall be controlled by independent flight computers.
 - 6.1.6.3 The SRAD device shall be successfully ground tested under a load approximating the load anticipated during flight.

6.2 RECOVERY AREA

- 6.2.1 Any hardware drifting outside the safe recovery area or onto White Sands Missile Range⁴ (WSMR) will either be abandoned or recovered at the team’s own expense.

⁴ WSMR is located approximately 16 km (10 miles) East from the NMSA Vertical Launch Area (VLA). No teams are allowed to enter WSMR lands.

6.3 INITIAL DEPLOYMENT EVENT

- 6.3.1 The initial deployment event shall occur at or near apogee.
- 6.3.2 Descent rate calculations shall be based on a launch site elevation of 1,400 m (4,600 ft) MSL.
- 6.3.3 The descent rate under drogue shall be between 20-40 m/s (65-131 ft/s).

6.4 MAIN DEPLOYMENT EVENT

- 6.4.1 The main deployment event for any recovery method shall occur at an altitude no higher than 450 m (1,500 ft) AGL.
- 6.4.2 Descent rate calculations shall be based on a launch site elevation of 1,400 m (4,600 ft) MSL.
- 6.4.3 The vehicle's descent rate at landing shall be <11 m/s (36 ft/s).

6.5 EJECTION GAS PROTECTION

- 6.5.1 The recovery system shall implement adequate protection (*e.g.*, fire resistant material, pistons, baffles, *etc.*) to prevent ejection energetics damaging recovery components including, but not limited to, shock cords and parachutes.

6.6 PARACHUTE SWIVEL LINKS

- 6.6.1 The recovery system rigging (*e.g.*, parachute lines, risers, shock cords, *etc.*) may implement appropriately rated swivel links at connections to relieve twist/torsion as the specific design demands.

6.7 PARACHUTE COLORATION AND MARKINGS

- 6.7.1 When separate parachutes are used for the initial and main deployment events, these parachutes shall be contrasting colors: from each other, blue sky, and clouds.
- 6.7.2 Through the use of visually distinct parachute colors and/or patterns, teams should be able to visually determine if a main was deployed at apogee, or was not deployed at the expected deployment altitude during descent (drogue only recovery).

6.8 NON-PARACHUTE/PARAFOIL RECOVERY SYSTEMS

- 6.8.1 Teams utilizing non parachute or parafoil based recovery methods shall notify ESRA of their intentions at the earliest possible opportunity and keep ESRA apprised of their progress.
- 6.8.2 ESRA reserves the right to impose additional requests for information and draft unique requirements depending on the team's specific design.
- 6.8.3 Range Safety personnel may deem the design as unsafe if it is determined that there is a reasonable probability the recovery could depart the safe recovery area.

6.9 REDUNDANT ELECTRONICS

- 6.9.1 Launch Vehicles shall implement completely independent and redundant recovery systems to include arming switches, sensors/flight computers, power supplies, redundant energetics (except as noted in Section 6.1.3), and electric initiators. A dual pole switch does not satisfy this requirement.

6.10 REDUNDANT COTS RECOVERY ELECTRONICS

- 6.10.1 At least one recovery system electronics subsystem shall implement a COTS flight computer (*e.g.*, StratoLogger, AIM, Kate, EasyMini, TeleMetrum, RRC3, Raven, *etc.*).
- 6.10.2 A COTS flight computer shall serve as the official altitude logging system specified in Section 2.5 of the IREC Rules & Requirements Document.
 - 6.10.2.1 This function may be provided by one of the flight computers satisfying 6.9.1.
 - 6.10.2.2 This function may be implemented by a separate flight computer⁵
 - 6.10.2.2.1 This flight computer may be armed and powered by the same switch and power supply as one of the flight computers satisfying 6.9.1.
- 6.10.3 A COTS flight computer shall fire either the primary or redundant energetic system.
- 6.10.4 To be considered COTS, the flight computer (including flight software) shall have been developed and validated by a commercial third party.
- 6.10.5 Commercially designed flight computer kits (*e.g.*, the Eggtimer or similar) are not permitted as COTS.

6.11 SRAD RECOVERY ELECTRONICS

- 6.11.1 Flight computer kits may be used as SRAD electronics.
- 6.11.2 Any SRAD flight computer assembled from separate COTS components shall be considered an SRAD system.
- 6.11.3 A COTS microcontroller running SRAD flight software shall be considered an SRAD system.
- 6.11.4 A COTS flight controller containing any student modifications to the base software or hardware shall be considered an SRAD system.
- 6.11.5 SRAD flight computers shall be documented in the progress reports.
- 6.11.6 Teams shall provide proof of function of SRAD flight computers including ground testing and flight testing before the competition.
- 6.11.7 SRAD recovery electronics shall take appropriate recognition of effects of noise and sensor error. Use of appropriate sensor filtering with testing is required.

6.12 SAFETY CRITICAL WIRING FOR RECOVERY SYSTEMS AND AIR-START MOTORS

- 6.12.1 Definition
 - 6.12.1.1 Safety critical wiring is any electrical wiring associated with recovery system deployment events, air start motors, location beacons (*e.g.*, GPS), and systems that can affect the rocket trajectory or stability.
 - 6.12.1.2 All safety critical wiring shall meet the requirements in this section and the safety critical wiring guidelines described in Appendix B of this document.
- 6.12.2 Cable Management

⁵ ESRA recommend teams implement a separate flight computer to fulfil this requirement. ESRA further recommends teams use the Featherweight Altimeters Blue Raven altimeter to meet this requirement. While neither a separate flight computer nor this specific flight computer are required for the 2025 IREC, it is anticipated both will be required beginning with the 2026 IREC.

- 6.12.2.1 All safety critical wiring shall implement a cable management solution (*e.g.*, wire ties, wiring, harnesses, cable raceways) which will prevent tangling and excessive free movement of significant wiring/cable lengths due to expected launch loads.
- 6.12.2.2 Wiring shall be labeled or color-coded to allow easy determination of the subsystem to which it is attached.
- 6.12.2.3 Wiring shall incorporate strain relief at all connections/terminals to prevent unintentional de-mating/disconnection.
- 6.12.3 Secure Wiring Connections
 - 6.12.3.1 All safety critical wiring/cable/terminal connections shall be sufficiently secure as to prevent disconnection during handling, transport, launch preparation and flight.
 - 6.12.3.2 Electrical connectors shall not be used as structural elements, *e.g.*, the mounting of daughterboards on a mainboard.
 - 6.12.3.3 Structural supports, *e.g.*, screws and standoffs, are required for daughterboard mounting.
 - 6.12.3.4 The use of twisted wires, even with the use of wire nuts or similar devices, to make or break flight essential connections is prohibited.

6.13 RECOVERY SYSTEM TESTING

- 6.13.1 Teams shall comply with all rules, regulations, and best practices imposed by the authorities at their chosen test location(s).
- 6.13.2 The following requirements concern verification testing of all recovery systems.
- 6.13.3 All recovery system ground tests shall be completed by the third progress report.
- 6.13.4 Ground test demonstration
 - 6.13.4.1 All recovery system mechanisms shall be successfully (without significant anomalies) tested prior to the IREC through one or more ground tests of key subsystems.
 - 6.13.4.2 Sensor electronics shall be functionally included in ground test demonstrations by simulating the environmental conditions under which their deployment functions are triggered, *i.e.*, expected ambient atmospheric conditions.
 - 6.13.4.3 Video(s) of the testing cycle(s) shall be included, or linked to, in the third progress report.
- 6.13.5 Flight Test Demonstration
 - 6.13.5.1 A flight test demonstration may be used in place of ground testing.
 - 6.13.5.2 In the case of such a flight test, the recovery system flown shall verify the intended design by implementing the same major subsystem components (*e.g.*, flight computers and parachutes) as will be integrated into the launch vehicle intended for the IREC (*i.e.*, a surrogate booster may be used).
 - 6.13.5.3 Video(s) of the test flight(s) shall be included, or linked to, in the third progress report.

6.14 STORED-ENERGY DEVICES – ENERGETIC DEVICE SAFING AND ARMING

- 6.14.1 For the purposes of this section energetics are defined as all stored-energy devices, other than propulsion systems, that have reasonable potential to cause bodily injury upon energy release.
- 6.14.2 An energetic device is considered made safe when two separate events are necessary to release the energy.
- 6.14.3 An energetic device is considered armed when only one event is necessary to release the energy.
- 6.14.4 All energetics shall be made safe until the rocket is in the launch position, at which point they may be armed at the direction of IREC personnel.
- 6.14.5 The following table lists some common types of stored-energy devices and overviews in what configuration they are considered non-energetic, made safe, or armed.

DEVICE CLASS	NON-ENERGETIC	MADE SAFE	ARMED
Igniters/Squibs	Small igniters/squibs, nichrome, wire or similar	Large igniters with leads shunted	Large igniters without shunted leads
Pyrogens (<i>e.g.</i> , black powder)	Very small quantities contained in non-shrapnel producing devices (<i>e.g.</i> , pyro-cutters or pyro-valves)	Large quantities with no igniter, shunted igniter leads, or igniter(s) connected to unpowered avionics	Large quantities with non-shunted igniter or igniter(s) connected to powered avionics
Mechanical Devices (<i>e.g.</i> , powerful springs)	De-energized/relaxed state, small devices, or captured devices (<i>i.e.</i> , no jettisoned parts)	Mechanically locked and not releasable by a single event	Unlocked and releasable by a single event
Pressure Vessels	Non-charged pressure vessels	Charged vessels with two events required to open main valve	Charged vessels with one event required to open main valve

- 6.14.6 Teams shall not bring amounts of pyrogenic materials to the event greater than the amount required for ground testing and the competition flight.
- 6.14.7 All stored-energy devices (aka energetics) used in recovery systems shall comply with the energetic device requirements defined in this section.

6.15 ARMING DEVICES

- 6.15.1 All energetic device arming features shall be externally accessible and controllable.
- 6.15.2 Access panels which may be secured for flight while the vehicle is in the launch position are acceptable.
- 6.15.3 All energetic device arming features shall be accessible without any person placing their head against the rocket or within 100 mm of the rocket.

- 6.15.4 All energetic device arming features shall be operable while wearing a face shield and any other required PPE.
- 6.15.5 All energetic device arming features shall be located on the airframe such that any inadvertent energy release will not impact personnel arming them⁶.

6.16 ARMING DEVICE VERIFICATION

- 6.16.1 Arming shall be verified without any person placing their head against the rocket or within 100 mm of the rocket. A stethoscope may be used to increase the distance between an audio source and a human ear.
- 6.16.2 Arming verification shall be designed to be completed in an environment with at least 76 dBA background noise plus at least 32 km/h (20 mph) wind.
- 6.16.3 Arming verification shall be designed to be completed while wearing a face shield and any other required PPE.

6.17 SRAD PRESSURE VESSELS

- 6.17.1 Teams shall comply with all rules, regulations, and best practices imposed by the authorities at their chosen test location(s).
- 6.17.2 The following requirements concern design and verification testing of SRAD and modified COTS pressure vessels.
 - 6.17.2.1 Unmodified COTS pressure vessels utilized for other than their advertised specifications will be considered modified, and subject to these requirements.
- 6.17.3 Relief Device
 - 6.17.3.1 All SRAD pressure vessels shall implement a relief device, set to open at no greater than the proof pressure specified in the following requirements.
 - 6.17.3.2 SRAD (including modified COTS) rocket motor propulsion system combustion chambers are exempted from this requirement.
- 6.17.4 Designed burst Pressure for Metallic Pressure Vessels
 - 6.17.4.1 All SRAD and modified COTS pressure vessels constructed entirely from isotropic materials (*e.g.*, metals) shall be designed to a burst pressure no less than 2 times the maximum expected operating pressure, where the maximum operating pressure is the maximum pressure expected during pre-launch, flight, and recovery operations.
- 6.17.5 Designed Burst Pressure for Composite Pressure Vessels
 - 6.17.5.1 All SRAD and modified COTS pressure vessels either constructed entirely from non-isotropic materials (*e.g.*, fiber reinforced plastics; FRP; aka composites), or implementing composite overwrap of a metallic vessel (aka composite overwrapped pressure vessels; COPV), shall be designed to a burst pressure no less than 3 times the maximum expected operating pressure, where the maximum operating pressure is the maximum pressure expected during pre-launch, flight, and recovery operations.
- 6.17.6 SRAD Pressure Vessel Testing

⁶ For example, the arming key switch for an energetic device used to deploy a hatch panel shall not be located at the same airframe clocking position as the hatch panel deployed by that charge.

- 6.17.6.1 Proof Pressure Testing – SRAD and modified COTS pressure vessels shall be proof pressure tested successfully to 1.5 times the maximum expected operating pressure for no less than twice the maximum expected system working time, using the intended flight article(s) (*e.g.*, the pressure vessel(s) used in proof testing must be the same one(s) flown at the IREC).
- 6.17.6.2 (Optional) Burst Pressure Testing
 - 6.17.6.2.1 There is no requirement for burst pressure testing, however a rigorous verification & validation test plan typically includes a series of both non-destructive (*i.e.*, proof pressure) and destructive (*e.g.*, burst pressure) tests.
 - 6.17.6.2.2 A series of burst pressure tests performed on the intended design will be viewed favorably; however, this will not be considered an alternative to proof pressure testing of the intended flight article.

6.18 BATTERIES CONTAINED IN THE ROCKET

- 6.18.1 Prohibited Batteries
 - 6.18.1.1 Lithium-Polymer (LiPo) batteries are not permitted due to fire hazard unless:
 - 6.18.1.1.1 Installed in the powered device by the manufacturer
 - 6.18.1.1.2 Recommended and supplied by the manufacturer
 - 6.18.1.1.3 Matching the specification determined by, and tested by, the manufacturer,
 - 6.18.1.2 Li-Ion batteries in a rectangular form factor and/or with plastic casing are prohibited.
 - 6.18.1.3 Wet cell lead acid batteries are prohibited.
 - 6.18.1.4 Any nuclear batteries
- 6.18.2 Allowed Batteries
 - 6.18.2.1 LiFePO₄ chemistry cells are allowed in any form factor and in any casing (plastic or metallic).
 - 6.18.2.2 NiMH (Nickel-Metal hydride) batteries are allowed in metal casing and any form factor.
 - 6.18.2.3 Alkaline (non-rechargeable) batteries are allowed in metal casing and any form factor.
 - 6.18.2.4 Other Li-Ion batteries are permitted if packaged in a cylindrical metallic casing.
 - 6.18.2.5 Lithium primary coin cell batteries in metal casing are permitted.
- 6.18.3 Teams should inquire about battery chemistries and form factors not listed here.

6.19 TRANSMITTERS CONTAINED IN THE ROCKET

- 6.19.1 This section shall apply to all COTS and SRAD transmitters contained in the rocket.
- 6.19.2 Any transmitter 200 mW or less output power may be used anywhere in the rocket.
- 6.19.3 Any transmitter over 200 mW output power shall not be used in a rocket containing SRAD avionics controlling energetics.

7.0 ACTIVE FLIGHT CONTROL SYSTEMS

7.1 RESTRICTED CONTROL FUNCTIONALITY

- 7.1.1 All launch vehicle active flight control systems shall be implemented strictly for pitch and/or roll stability augmentation, or for aerodynamic braking.
- 7.1.2 Under no circumstances will a launch vehicle entered in the IREC be actively guided towards a designated spatial target.
- 7.1.3 ESRA reserves the right to make additional requests for information and draft unique requirements depending on the team's specific design.
- 7.1.4 A neutral state is defined as one which does not apply any moments to the launch vehicle (*e.g.*, aerodynamic surfaces trimmed or retracted, gas jets off, *etc.*).

7.2 UNNECESSARY FOR STABLE FLIGHT

- 7.2.1 Launch vehicles implementing active flight controls shall be naturally stable without those controls being implemented (*e.g.*, the launch vehicle may be flown with the control actuator system (CAS) – including any control surfaces – either removed or rendered inert and mechanically neutral, without becoming unstable during ascent).
- 7.2.2 Attitude control systems (ACS) shall only mitigate small perturbations which affect the trajectory of a stable rocket that implements only fixed aerodynamic surfaces for stability.
- 7.2.3 Stability is defined in Section 10.2 of this document.
- 7.2.4 ESRA reserves the right to make additional requests for information and draft unique requirements depending on the team's specific design.

7.3 DESIGNED TO FAIL SAFE

- 7.3.1 Control actuator systems (CAS) shall default to a neutral state whenever either an abort signal is received for any reason, primary system power is lost, or the launch vehicle's attitude exceeds 30° from its launch elevation.

7.4 BOOST PHASE DORMANCY

- 7.4.1 Control actuator systems (CAS) shall remain in a neutral state until one of the following conditions is met:
 - 7.4.1.1 The launch vehicle's boost phase has ended (*i.e.*, all propulsive stages have ceased producing thrust).
 - 7.4.1.2 The launch vehicle has crossed the point of maximum aerodynamic pressure (max Q) in its trajectory.
 - 7.4.1.3 The launch vehicle has reached the following:
 - 7.4.1.3.1 For 30K flights: an altitude of 6,000 m (19,600 ft) AGL.
 - 7.4.1.3.2 For 10K flights: an altitude of 2,000 m (6,500 ft) AGL.

7.5 ACTIVE FLIGHT CONTROL SYSTEM ELECTRONICS

- 7.5.1 All active control systems shall comply with the "safety critical wiring" requirements, 6.12.

7.5.2 Flight control systems are exempt from the requirement for COTS redundancy, given that such components are generally unavailable as COTS to the amateur high-power rocketry community.

7.6 ACTIVE FLIGHT CONTROL SYSTEM ENERGETICS

7.6.1 All stored-energy devices used in an active flight control system (aka energetics) shall comply with the energetic device requirements defined in Section 6.15 of this document.

8.0 AIRFRAME STRUCTURES

8.1 ADEQUATE VENTING

8.1.1 Launch vehicles shall be adequately vented to prevent internal pressures developing during flight and causing either damage to the airframe or any other unplanned configuration changes.

8.2 OVERALL STRUCTURAL INTEGRITY

8.2.1 Launch vehicles shall be constructed to withstand the operating stresses and retain structural integrity under the conditions encountered during handling and transportation and during rocket flight.

8.2.2 Teams shall ensure that the fin flutter velocity of the rocket is at least 50% higher than the maximum expected rocket velocity.

8.3 MATERIAL PROHIBITIONS

8.3.1 Rockets shall be built using lightweight materials, *e.g.*, fiberglass and carbon fiber, or when necessary ductile lightweight metals, *e.g.*, aluminum, and construction techniques suitable for the planned flight.

8.3.2 PVC (and similar low-temperature polymers), Public Missiles Ltd. (PML) Quantum Tube, and steel (including stainless-steel) shall not be used in any rocket airframe structure. This includes fins, body tubes, and nosecones.

8.3.3 PVC (and similar low-temperature polymers), stainless steel, or other frangible materials shall not be used for a solid or hybrid propulsion system combustion chamber.

8.3.4 Environmentally hazardous materials shall not be used as ballast. This includes lead, mercury, and uranium.

8.4 LOAD BEARING EYE BOLTS AND U-BOLTS

8.4.1 All load bearing eye bolts shall be of the closed-eye, forged type.

8.4.2 All load bearing eye bolts, U-bolts, and links shall be steel.

8.4.3 This requirement extends to any bolt and eye-nut assembly used in place of an eyebolt.

8.4.4 Stainless steel components (eye bolts, U-bolts, links, *etc.*) are permissible for use in recovery systems.

8.5 JOINTS IMPLEMENTING COUPLING TUBES

8.5.1 Airframe-to-coupler sliding joints intended to separate during a recovery event

8.5.1.1 Joints shall be designed such that the coupling tube extends no less than 1 body tube diameter (1 caliber) into the airframe section from which the coupler will separate during flight.

8.5.2 Joints not intended to separate during flight

8.5.2.1 Joints shall be designed such that the coupling tube extends into the mating component to the lesser of 1 body tube diameter (1 caliber) or the maximum depth possible by the design of the mating component.

8.5.2.2 Joints shall be affixed by mechanical fasteners and/or permanent adhesive.

- 8.5.3 Regardless of implementation (*e.g.*, RADAX or other join types) airframe joints shall prevent bending, see <https://www.osti.gov/biblio/5007820>.

8.6 RAIL BUTTONS

- 8.6.1 Rail buttons shall implement “hard points” for sliding mechanical attachment of the rocket to the IREC supplied 1515 launch rail, serving to guide the rocket during the initial phase of boost until the rocket achieves sufficient velocity for the fins to provide aerodynamic stabilization.
- 8.6.2 A minimum of two (2) rail buttons shall be used.
- 8.6.3 Airframe attachment points for rail buttons shall be reinforced.
- 8.6.4 Rail buttons shall be attached using at least one metallic fastener through the reinforced airframe.
- 8.6.5 Adhesive only attachment is not permitted.
- 8.6.6 Fly-away rail guides are not permitted.
- 8.6.7 Rail buttons 3D printed in a polymer material are not permitted.
- 8.6.8 Conformal adhesively-attached rail guides of a linear shape sliding in the slot in the launch rail are not permitted.
- 8.6.9 The rail buttons shall be capable of supporting the launch vehicle’s fully loaded weight while the rocket is horizontal and hung from a rail (underslung).
- 8.6.10 Rail button placement shall not result in the rail blocking access to arming electronics.
- 8.6.11 Teams utilizing launch towers shall provide the launch tower and are exempt from the Rail Button requirements.

8.7 IDENTIFYING MARKINGS

- 8.7.1 All rockets shall be labeled with the team name, number, and GPS tracking frequency.
- 8.7.2 This label shall be duplicated on each part of the rocket which could separate either as designed or accidentally.
- 8.7.3 The booster airframe, shall prominently display the Team ID number forward of each fin. The digits of the Team ID shall be marked in sequence, longitudinally, from fore to aft along the booster airframe. See Appendix F for an example.
- 8.7.3.1 Individual digits shall be oriented with their vertical axis in-line with the longitudinal axis of the rocket and shall be readable with the rocket in a vertical position.
- 8.7.3.2 The Team ID digits shall each be at least 75 mm (3 in) high, at least 12 mm (½ in) stroke width, and a solid color that clearly contrasts with a solid background color.
- 8.7.3.3 The team identity should be clear to livestream viewers when the rocket is on the pad.

8.8 OTHER MARKINGS

- 8.8.1 There are no requirements for airframe coloration or markings beyond those specified in Section 8.7 of this document; however, ESRA offers the following recommendations to student teams.

- 8.8.2 Mostly white or lighter tinted color (*e.g.*, yellow, red, orange, *etc.*) airframes are especially conducive to mitigating some of the solar heating experienced in the IREC launch environment.
- 8.8.3 High-visibility schemes (*e.g.*, high-contrast black, orange, red, *etc.*) and roll patterns (*e.g.*, contrasting stripes, *etc.*) may allow ground-based observers to more easily track and record the launch vehicle's trajectory with high-power optics.
- 8.8.4 Any form of green, brown, or other colors associated with camouflage patterns is highly discouraged.

9.0 PAYLOAD

9.1 PAYLOAD RECOVERY

- 9.1.1 Payloads may be deployable independent of the launch vehicle, remain inside the launch vehicle airframe, or be deployed and remain attached to the launch vehicle throughout the flight.
- 9.1.2 Deployable payloads not remaining attached to the launch vehicle airframe shall:
 - 9.1.2.1 Incorporate an independent recovery system, reducing the payload's descent velocity to less than 11 m/s (36 ft/s) at touchdown.
 - 9.1.2.2 Contain a GPS tracking system that complies with section 4.
- 9.1.3 Deployable payloads implementing a parachute or parafoil based recovery system are not required to comply with the dual-event requirement.
- 9.1.4 Deployable payloads may not implement gliders, drones, balloons, or any other UAS system.

9.2 PAYLOAD RECOVERY SYSTEM ELECTRONICS AND SAFETY CRITICAL WIRING

- 9.2.1 Payloads implementing independent recovery systems shall comply with the same requirements as the launch vehicle for “redundant electronics” and “safety critical wiring”.
- 9.2.2 Payload batteries shall conform to requirements in 6.18.

9.3 PAYLOAD RECOVERY SYSTEM TESTING

- 9.3.1 Payloads implementing independent recovery systems shall comply with the same requirements as the launch vehicle for “recovery system testing”.

9.4 PAYLOAD ENERGETIC DEVICES

- 9.4.1 Payloads shall not include any form of pyrotechnics. These include but are not limited to rocket motors, exploding bolts, or other energetics.

9.5 PAYLOAD IDENTIFYING MARKINGS

- 9.5.1 All payloads shall be labeled with the team name, number, and GPS tracking frequency.
- 9.5.2 This label shall be duplicated on each part of the payload which could separate either as designed or accidentally.

10.0 LAUNCH AND ASCENT TRAJECTORY REQUIREMENTS

10.1 LAUNCH AZIMUTH AND ELEVATION

- 10.1.1 Launch vehicles will nominally launch at an elevation angle of $84^{\circ} \pm 2^{\circ}$ and a launch azimuth defined by competition officials at the IREC.
- 10.1.2 Range Safety Officers reserve the right to require certain vehicles' launch elevation be lower or higher if flight safety issues are identified during pre-launch activities.
- 10.1.3 Competition officials may allow staged flights to launch at $87^{\circ} \pm 2^{\circ}$.

10.2 LAUNCH STABILITY

- 10.2.1 Teams should design their rockets to attain a rail departure velocity of at least 30 m/s (100 ft/s).
- 10.2.2 Teams unable to meet 10.2.1 may use detailed analysis to prove stability is achieved at a lower rail departure velocity. Alternatively, multiple computer simulations may be used, but must evaluate stability under a variety of launch conditions.
 - 10.2.2.1 Under no circumstances shall rail departure velocity be less than 15m/s (50 ft/s).
- 10.2.3 Departing the launch rail is defined as the instant at which the launch vehicle first becomes free to move about the pitch, yaw, or roll axis.

10.3 ASCENT STABILITY

- 10.3.1 Launch vehicles shall maintain a dynamic stability margin of at least 1.5 body calibers, regardless of Cg movement and/or shifting center of pressure Cp location, from launch through the first recovery system deployment event.

10.4 OVER-STABILITY

- 10.4.1 Launch vehicles shall not be “over-stable” during their ascent, defined as having a static stability margin >4 calibers or a dynamic stability margin during flight >6 calibers.

11.0 ESRA PROVIDED LAUNCH SUPPORT EQUIPMENT

11.1 ESRA-PROVIDED LAUNCH RAILS

- 11.1.1 All teams competing in the solids (COTS or SRAD) categories shall use IREC supplied launch control systems.
- 11.1.2 ESRA shall provide launch rails measuring at least 5.2 m (17 ft) long, 1.5" x 1.5" (aka 1515) aluminum guide rails of the 80/20® type, see <https://8020.net/>.
- 11.1.3 Rockets shall be loaded horizontally from the top of the guide rail and the rail then erected to the required launch elevation.
- 11.1.4 Once erected, the launch vehicle shall be supported vertically by a submerged mechanical stop in the rail.
 - 11.1.4.1 The position of the mechanical stop may be adjusted.
- 11.1.5 Teams whose designs anticipate requiring a longer launch rail to achieve stability during launch shall provide their own launch pad.

11.2 ESRA-PROVIDED LAUNCH CONTROL SYSTEM

- 11.2.1 The IREC will utilize a Wilson F/X Wireless Launch Control System consisting of one LCU-64x launch control unit and PBU-8w encrypted wireless pad relay boxes.

11.3 TEAM-PROVIDED LAUNCH SUPPORT EQUIPMENT

- 11.3.1 Teams are allowed to provide their own launch rail or towers.
- 11.3.2 Team-provided launch rails or towers shall be subject to safety review by ESRA personnel prior to use. Rails or towers deemed unsafe will not be permitted. Teams in this situation will be allowed to use ESRA-provide launch rails.
- 11.3.3 Teams should make their launch support equipment human-portable over a distance of at least 100 m (328 ft).
- 11.3.4 Hybrid launch controllers shall include instrumentation for monitoring oxidizer fill level. This instrumentation shall function in potentially low relative humidity of the launch site (<5%). Instrumentation relying on condensation of water in the air is unlikely to function.
- 11.3.5 Frequency Coordination
 - 11.3.5.1 All team-provided launch control systems utilizing wireless communication shall manage frequency allocations with MCC.
 - 11.3.5.2 All team-provided launch control systems utilizing wireless communication shall be able to displace their antennas at least 30 meters in any direction from the launch point.
 - 11.3.5.3 Teams should elevate any antennas to provide line of sight clearance above bushes and terrain
- 11.3.6 Ground Power
 - 11.3.6.1 Ground power umbilicals are permitted.
 - 11.3.6.2 Team ground power equipment shall not be connected to any ESRA equipment.
 - 11.3.6.3 Generators are prohibited.
 - 11.3.6.4 Excessive noise from the ground power support equipment (affecting launch operations) is prohibited.

11.3.6.5 Teams shall collect ground power equipment as soon as practical after use, *i.e.*, the next time the pad bank opens for access.

11.3.6.6 Team ground power equipment shall be labeled with team number and contact information.

11.3.6.7 Wet cell lead acid batteries are prohibited.

11.4 OPERATIONAL RANGE

11.4.1 All team-provided launch control systems shall be electronically operated and have a minimum operational range of no less than 610 m (2,000 ft) from the launch rail.

11.4.2 The maximum operational range is defined as the range at which abort and launch may be commanded reliably.

11.5 FAULT TOLERANCE AND ARMING

11.5.1 All team-provided launch control systems shall be at least single fault tolerant by implementing a removable safety interlock (*i.e.*, a jumper or key to be kept in possession of the arming crew during arming) in series with the launch switch.

11.5.2 Appendix C of this document provides general guidance on assuring fault tolerance in high power rocketry launch control systems.

11.5.3 Hybrid launch controllers shall include a failsafe mechanism providing automatic venting of oxidizer in the event of power or communication loss during fill.

11.6 SAFETY CRITICAL SWITCHES

11.6.1 All team-provided launch control systems shall implement ignition switches of the momentary, normally open (aka “deadman”) type so that they will remove the signal when released.

11.6.2 Mercury or “pressure roller” switches are not permitted anywhere in team-provided launch control systems.

APPENDIX A: ACRONYMS, ABBREVIATIONS, AND TERMS

ACRONYMS & ABBREVIATIONS	
ACS	Attitude Control System
AGL	Above Ground Level
APCP	Ammonium Perchlorate Composite Propellant
AWG	American Wire Gauge
CAS	Control Actuator System
CFR	Code of Federal Regulations
Cg	Center of Gravity
CONOPS	Concept of Operations
COPV	Composite Overwrapped Pressure Vessel
COTS	Commercial Off-the-Shelf
Cp	Center of Pressure
EIRP	Equivalent Isotropic Radiated Power
ESRA	Experimental Sounding Rocket Association
FoR	Flyer of Record
FRP	Fiber Reinforced Plastic
IREC	International Rocket Engineering Competition
LOX	Liquid Oxygen
MCC	Mission Control Center
MCOTS	Modified Commercial Off The Shelf
MSL	Mean Sea Level
NFPA	National Fire Protection Association
SRAD	Student Researched & Developed
TBD	To Be Determined
TBR	To Be Resolved
TRA	Tripoli Rocketry Association

TERMS	
Amateur Rocket	14 CFR, Part 1, 1.1 defines an amateur rocket as an unmanned rocket that is "propelled by a motor, or motors having a combined total impulse of 889,600 Newton-seconds (200,000 pound-seconds) or less, and cannot reach an altitude greater than 150 kilometers (93.2 statute miles) above the earth's surface".
Body Caliber	A unit of measure equivalent to the diameter of the launch vehicle airframe in question.
Excessive Damage	Excessive damage is defined as any damage to the point that, if the systems intended consumables were replenished, it could not be launched again safely. Intended Consumables refers to those items which are - within reason - expected to be serviced/replaced following a nominal mission (<i>e.g.</i> , propellants, pressurizing gasses, energetic devices), and may be extended to include replacement of damaged fins or other airframe components specifically designed for easy, rapid replacement if such components are on hand and can reasonably be replaced within 30 minutes.
FAA Class 2 Amateur Rocket	14 CFR, Part 101, Subpart C, 101.22 defines a Class 2 Amateur Rocket (aka High Power Rocket) as "an amateur rocket other than a model rocket that is propelled by a motor or motors having a combined total impulse of 40,960 Newton-seconds (9,208 pound-seconds) or less."
Non-toxic Propellants	For the purposes of the IREC, the event organizers consider ammonium perchlorate composite propellant (APCP), potassium nitrate and sugar (aka "rocket candy"), nitrous oxide, liquid oxygen (LOX), hydrogen peroxide, kerosene, propane and similar, as non-toxic propellants. Toxic propellants are defined as requiring breathing apparatus, special storage and transport infrastructure, or extensive personal protective equipment, <i>etc.</i>

APPENDIX B: SAFETY CRITICAL WIRING GUIDELINES

Introduction

- With the aim of supporting recovery reliability and overall safety, this Appendix sets out guidelines for all safety critical wiring. This is defined as wiring associated with recovery system deployments, any air-start rocket motors, location beacons (*e.g.*, GPS), and any systems that can affect the rocket trajectory or stability.
- The wiring techniques described here are suggested for inspection and ease of field repair. While non-critical wiring is outside the scope of this white paper the practices described herein are recommended.

Hazard Identification

- Any electronic system that utilizes voltages 50 volts (AC or DC) or higher shall be identified with the following warning external to the electronics enclosure; "CAUTION: High voltage inside. Internal access by team personnel only."

Wiring Guidelines

- All airborne wiring shall be stranded, insulated, 22 American Wire Gauge (AWG) or lower numerical AWG (the lower the AWG wire gauge the larger the conductor diameter) as appropriate (based on industry practice) to conduct expected currents. Copper conductors are required except as noted below.
 - Copper conductors plated with either silver or tin (entire wire, not just the ends) are desirable but not required.
 - When an off-the-shelf component includes flying leads, those leads may be used unmodified. For example, an E-match may contain solid wire, a battery connector may integrate 26 AWG wire, *etc.*
 - Stranded wire of a smaller diameter than 24 AWG may be used only when needed by an off-the-shelf component. For example, if the terminal block on an altimeter is sized to accept 24 AWG wires then that is the size of wire that should be used for that portion of the circuit.
- Wire should be stripped only with a wire stripping tool of the correct gauge. Any severed strands are cause for rejection.
- Each end of a wire should be terminated in one of the following approved methods:
 - Crimped into a crimp terminal (preferred). This includes crimp terminals on multi-conductor connectors such as 9-pin D-sub connectors (see table below).
 - Screwed into a binding screw terminal (acceptable).
 - Wires should be terminated into a terminal block, only if a piece of off-the-shelf equipment (*i.e.*, an altimeter) has built-in terminal blocks and so there is no other choice. Two-piece terminal blocks must be positively secured together – friction fit is insufficient.
 - Removal of wire strands to allow a wire to fit into a smaller hole or terminal is prohibited. Consider a smaller diameter conductor or different terminal type.

- Wires will be terminated by soldering only if a piece of off-the-shelf equipment (*e.g.*, an arming switch) has built-in solder terminals and so there is no other choice. The reliability of solder joints cannot be fully established by visual inspection alone.
- All crimp operations shall be performed with the correct tooling, using crimp terminals sized for the appropriate wire gauge.
 - Where multiple wires are crimped into a single terminal, calculate the effective gauge (for example, two 22 AWG are effectively 19 AWG) and use the appropriately sized terminal.
- Terminals with insulated plastic sleeves (usually color-coded to indicate barrel size) should be avoided because of the difficulty of inspection.
 - If a terminal is supplied with an insulated plastic sleeve it may be removed and clear heat shrink applied instead.
 - Insulated plastic sleeves on terminals are typically not required if they are mounted properly in barrier blocks. If insulation is needed, use clear heat-shrink tubing.
- When a bare wire is held down by a binding screw terminal the wire shall make a 180-degree hook, and strands shall be visible exiting the screw head. Only one wire shall be permitted per screw.
 - The wire bend shall be clockwise, so that it will tighten as the screw is torqued.
- When ring or spade terminals are held down by binding screw terminals, a maximum of two terminals are allowed per screw.
- A maximum of three wires shall be crimped into a single terminal barrel. Butt-splice terminals are considered to have separate barrels on each end.
- If two or more wires must be joined, one of the following approved methods should be used:
 - Crimp a ring terminal onto each wire, and then screw them into a barrier block. Add approved barrier block jumper pieces if many wires must be joined.
 - Screw the bare wire under a binding head screw in a barrier block. Add approved barrier block jumper pieces if many wires must be joined.
 - Crimp the wires into an uninsulated butt-splice terminal, and then insulate with clear heat-shrink tubing.
- Any wire-twisting splice method (including wire nuts) is explicitly forbidden.
- All wire terminations shall be inspected before flight.
 - Inspections will be visual to determine compliance with this document.
 - All terminations will be examined for exposed conductors that may have a potential for electrical shorts.
 - All terminations will be pull tested by exerting a moderate pull on the wiring to verify that it remains attached.

- All insulating tubing (usually heat-shrink) shall be transparent. This allows inspection of the underlying hardware.
 - No tape, glue or RTV shall be used to insulate or bundle any element of the wire harness.

Connector/Harness Guidelines

- Connectors shall be identified by labels and/or color coding to allow determination of the associated system and mating parts.
- Connectors (except coaxial connectors) shall use crimp contacts unless no alternative can be procured.
 - Coaxial connectors may be soldered.
- Mated connectors (except threaded coaxial connectors) shall utilize a positive locking mechanism to keep the two halves mated under vibration and tension.
 - If the mated connectors do not have a positive locking mechanism built-in, they shall utilize an external means of preventing connection separation, *e.g.*, tie wraps, lacing, mechanical clamps.
 - Threaded coaxial connectors will be checked for finger tightness.
- Plastic connector latches are allowed but subject to inspection for damage and engagement.
- Power connectors shall be polarized to prevent reversed power application.
- Good practice recommends that individual wires be bundled together to make a harness (factory multi-conductor wiring in a common outer jacket is acceptable).
 - Safety critical harnesses shall be kept separate from payload harnessing (as applicable).
 - Bundling may be accomplished by:
 - A light twist (for mechanical reasons only, no EMC mitigation is intended).
 - Short (1 cm) lengths of clear heat-shrink tubing, zip-ties, or lacing every 5 cm.
 - Wire mesh sleeving, provided it allows for inspection of the wiring inside.
- The harness may be supported by plastic P-clamps, tie bases, or by tie wraps to structure. Harness routing shall not be in contact with sharp edges, *e.g.*, screw threads, that may damage wiring.
- All items that are connected by the harness (barrier blocks, sensors, batteries, actuators, switches, *etc.*) should be rigidly fixed to the rocket structure so that they cannot move.
 - Rigid fixing implies attachment with clamps using threaded fasteners or a solid glue bond. Cable ties and/or tape are not acceptable examples of rigid fixing.
 - All wiring should have strain relief (small amount of slack) to prevent terminations and connections from demating.
- Batteries should be mounted and connected appropriately:
 - "Velcro" (or similar hook and loop material) and/or tie wraps shall not be used as the sole method of mounting batteries.

- Batteries that are subject to puncture damage should be mounted in a fashion and location to mitigate the likelihood of such damage during a hard landing or other high impact event.
- 9V alkaline batteries shall be secured to prevent motion and connected using proper snap terminals.
 - Batteries shall be mounted in a direction and manner that prevents acceleration forces from disconnecting the battery connector.
- Gel-cell lead acid battery connections shall be color coded (typically red for positive, black for negative) to avoid reversed connection polarity. Insulated "faston" terminals may be used in this application subject to visual inspection and pull testing.
 - Gel cell batteries, because of their weight, will be inspected for rigid and captive mounting. Tie wraps and/or Velcro hook and loop alone is not acceptable.
- Cylindrical batteries (AAA, AA, C, D, 18650, *etc.*) may be mounted into commercial holders. Battery holders, if used, shall be rigidly secured to the structure, and the batteries shall then be strapped (*e.g.*, tie wrap, lacing) into the holders.
 - Battery holders shall be mounted in a direction and manner that prevents acceleration forces from compressing contact springs.

Circuit Board Guidelines

- All components greater than 7g shall be staked to prevent motion under acceleration.
 - The use of conformal coatings is suggested to provide a degree of staking for all components and to avoid electrical shorts.
- All socketed components (*e.g.*, integrated circuits) and press-fit contacts shall be positively restrained so that they cannot come loose under vibration.
- Wire wrap, through-hole solder, and surface-mount solder are acceptable fabrication methods.
- Solderless breadboards (also known as plug-in breadboards) shall not be used.
- Any commercial board for the high-power rocketry market should be considered to be of sufficient quality, provided it is in an undamaged factory state.
- The connector between the motherboard and daughterboards shall not be the sole means of support. Mechanical supports for the daughterboard are required.
- Cuts and jumpers are permitted if the jumpers are staked to prevent damage.

Recommended Sources

- Suggested components can be purchased from Digikey, Mouser, Omron, and Amazon that will help to satisfy the wiring guidelines.
- These are recommendations only, and you are free to choose other parts and buy from other suppliers.

- Look up the catalog pages associated with each Digikey or Mouser number to find similar parts of different sizes.

<u>Part</u>	<u>Number</u>	<u>Notes</u>
Wire	Digikey A5855W-100-ND	This is good 22-gauge, tinned, Teflon insulated wire. Cold-flow is a long-term consideration, but shouldn't be a problem for a short lifetime rocket.
Wire	Digikey C2016L-100-ND	22-gauge tinned PVC-insulated wire. Note that the "L" designates the insulation color (other colors are B,R,A,Y,N,W)
Wire	Digikey W120-100-ND Digikey W121-100-ND	2-conductor, 22-gauge 3-conductor, 22-gauge
Wire	Amazon "Tinned marine grade wire"	18-gauge, available in 35-ft or 100-ft rolls
Ring terminals, uninsulated	Digikey A27021-ND (#6 hole)	The Solistrand series is a high quality terminal. Various crimp tools are available. You get what you pay for – the expensive ones are very nice, but the basic ones will do in a pinch.
Butt-splice terminal	Digikey A09012-ND	Another Solistrand series terminal
"Faston" terminal	Digikey 298-10011-ND (check size)	These terminals are useful for connecting switches, gel cell batteries, and many automotive devices
9V battery holder, with solder terminals	Digikey 708-1409-ND	Screw this holder to your chassis, and then cable tie the battery in.
9V battery connector, snap on	Digikey BS12I-ND	Cable tie connector to battery and battery to chassis.
4 AA battery holder	Digikey 708-1399-ND	This is a nice enclosed battery box for 4 AA cells
P-clamp	Digikey 7624K-ND (check size)	This particular unit is for a 0.25" dia. harness. Select the correct size.
Heat-shrink tubing	Digikey A014C-4-ND (check size) Mouser 650-RNF100 (check size)	Material is clear polyolefin with low shrink temperature. Shrink with hot-air gun or oven.
Barrier block (double row)	Digikey CBB206-ND Mouser 538-2140 or 4140 (0.375" pitch), 538-2141 or 4141 (0.438" pitch)	Available in a range of lengths. Can accept ring or spade terminals (preferred), or bare wire (acceptable).

Barrier block jumper	Digikey CBB314-ND	Connect adjacent strips when many wires need to be connected together
D-sub connectors (9 contact)	Digikey A31886-ND (male shell) Digikey A34104-ND (female shell) Digikey A1679-ND (male pins) Digikey A1680-ND (female pins)	The connectors and contacts are cheap, but the crimp tools are expensive.
D-sub fixing hardware	Digikey MDVS22-ND (screw) Digikey MDVS44-ND (socket)	These kits convert the D-sub friction fit into a proper positive lock.
MIL-C-38999 connectors	Digikey 956-1017-ND (13 pin panel mount receptacle with pins) Digikey 956-1020-ND (13 pin plug with sockets)	These connectors approach the style and quality used on orbital launch vehicles. Extremely robust, but very expensive!
Switch for pull-pin	Omron SS-5G	This switch is rated to 30G. Available direct or as part of some commercial pull-pin switches

APPENDIX C: FIRE CONTROL SYSTEM DESIGN GUIDELINES

Introduction

- The following Appendix is written to illustrate safe fire control system design best practices and philosophy to student teams participating in the IREC. When it comes to firing (launch) systems for large amateur rockets, safety is paramount. This is a concept that everyone agrees with, but it is apparent that few truly appreciate what constitutes a “safe” firing system. Whether they’ve ever seen it codified or not, most rocketeers understand the basics:
 - 1.1 The control console should be designed such that two deliberate actions are required to fire the system.
 - 1.2 The system should include a power interrupt such that firing current cannot be sent to the firing leads while personnel are at the pad and this interrupt should be under the control of personnel at the pad.
 - 1.3 These are good design concepts and if everything is working as it should they result in a perfectly safe firing system. But “everything is working as it should” is a dangerous assumption to make. Control consoles bounce around in the backs of trucks during transport. Cables get stepped on, tripped over, and run over. Switches get sand and grit in them. In other words, components fail. As such, there is one more concept that should be incorporated into the design of a firing system:
 - 1.3.1 The failure of any single component should not compromise the safety of the firing system.

Proper Fire Control System Design Philosophy

- Let us examine a firing system that may at first glance appear to be simple, well designed, and safe (Figure 1). If everything is functioning as designed, this is a perfectly safe firing system, but let’s examine the system for compliance with proper safe design practices.
- The control console should be designed such that two deliberate actions are required to launch the rocket. Check! There are actually three deliberate actions required at the control console: (1) insert the key, (2) turn the key to arm the system, (3) press the fire button.
- The system should include a power interrupt such that ignition current cannot be sent to the firing leads while personnel are at the pad and this interrupt should be under control of personnel at the pad. Check and check! The Firing relay effectively isolates the electric match from the firing power supply (battery) and as the operator at the pad should have the key in his pocket, there is no way that a person at the control console can accidentally fire the rocket.

- But all of this assumes that everything in the firing system is working as it should. Are there any single component failures that can cause a compromise in the safety of this system? Yes. In a system that only has five components beyond the firing lines and e-match, three of those components can fail with potentially lethal results.

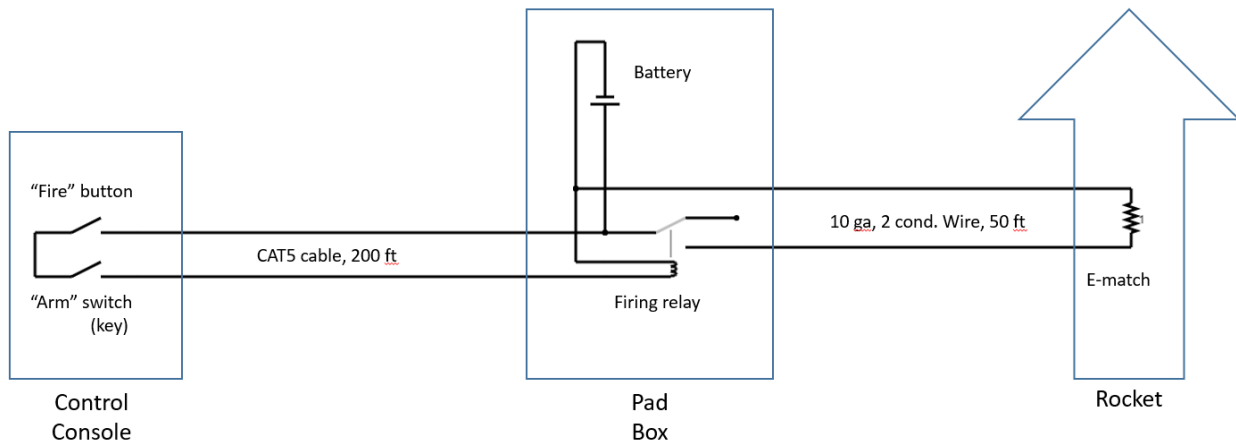

Figure 1: A simple high current fire control system.

Firing Relay

- If the firing relay was stuck in the ON position: The rocket would fire the moment it was hooked to the firing lines.
- This is a serious safety failure with potentially lethal consequences as the rocket would be igniting with pad personnel in immediate proximity.

Arming Switch

- If the arm key switch failed in the ON position simply pushing the fire button would result in a fired rocket whether intentional or not. This is particularly concerning as the launch key – intended as a safety measure controlled by pad personnel – becomes utterly meaningless.
- Assuming all procedures were followed, the launch would go off without a hitch. Regardless, this is a safety failure as only one action (pressing the fire button) would be required at the control console to launch the rocket. Such a button press could easily happen by accident.
- If personnel at the pad were near the rocket at the time we are again dealing with a potentially lethal outcome

CAT5 Cable

- If the CAT5 cable was damaged and had a short in it the firing relay would be closed and the rocket would fire the moment it was hooked to the firing lines. This too is a potentially lethal safety failure.

Notice that all three of these failures could result in the rocket being fired while there are still personnel in immediate proximity to the rocket. A properly designed firing system does not allow single component failures to have such drastic consequences. Fortunately, the system can be fixed with relative ease.

Consider the revised system (Figure 2). It has four additional features built into it: (1) A separate battery to power the relay (as opposed to relying on the primary battery at the pad), (2) a flip cover over the fire button, (3) a lamp/buzzer in parallel with the firing leads (to provide a visual/auditory warning in the event that voltage is present at the firing lines), and (4) a switch to short the firing leads during hookup (pad personnel should turn the shunt switch ON anytime they approach the rocket).

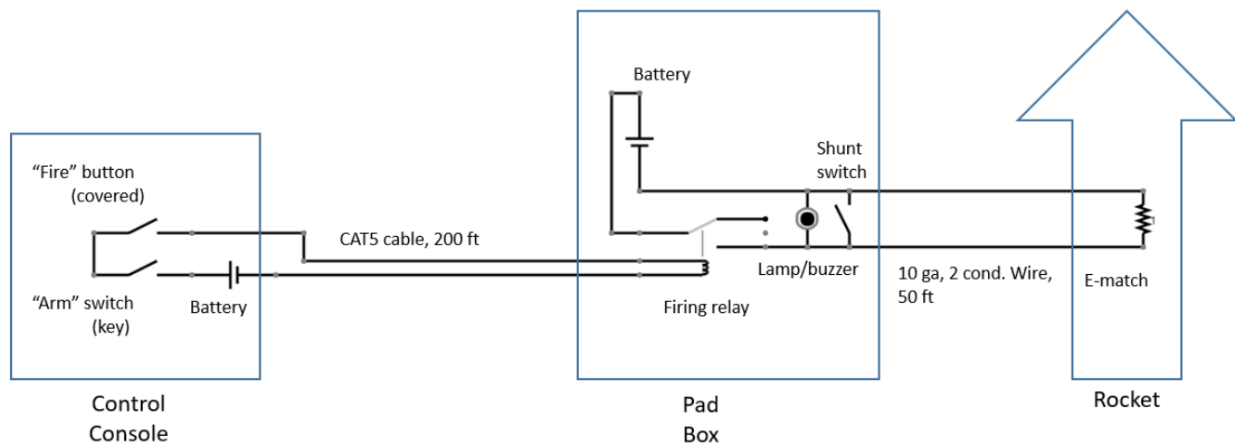

Figure 2: An improved high current fire control system.

In theory, these simple modifications to the previous firing circuit have addressed all identified single point failures in the system. The system has 8 components excluding the firing lines and e-match (part of the rocket itself). Can the failure of any of these components cause an inadvertent firing? That is the question. Let us examine the consequences of the failure of each of these components.

Fire Button

- If the fire button fails in the ON position, there are still two deliberate actions at the control console required to fire the rocket. (1) The key must be inserted into the arming switch, and (2) the key must be rotated.

- The firing will be a bit of a surprise, but it will not result in a safety failure as all personnel should have been cleared by the time possession of the key is transferred to the Firing Officer.

Arm Switch

- If the arm switch were to fail in the ON position, there are still two deliberate actions at the control console required to fire the rocket. (1) The cover over the fire button would have to be removed, and (2) the fire button would have to be pushed.
- This is not an ideal situation as the system would appear to function flawlessly even though it is malfunctioning and the key in the possession of personnel at the launch pad adds nothing to the safety of the overall system.
- It is for this reason that the shunting switch should be used. Use of the shunting switch means that any firing current would be dumped through the shunting switch rather than the e-match until the pad personnel are clear of the rocket.
- Thus, personnel at the pad retain a measure of control even in the presence of a malfunctioning arming switch and grossly negligent use of the control console.

Batteries

- If either battery (control console or pad box) fails, firing current cannot get to the e-match either because the firing relay does not close or because no firing current is available.
- No fire means no safety violation.

CAT5 Cable

- If the CAT5 cable were to be damaged and shorted, the system would simply not work as the current intended to pull in the firing relay would simply travel through the short. No fire means no safety violation.

Firing Relay

- If the firing relay fails in the ON position the light/buzzer should alert the pad operator of the failure before he even approaches the pad to hook up the e-match.

Shunt switch, Lamp/Buzzer

- These are all supplementary safety devices.
- They are intended as added layers of safety to protect and/or warn of failures of other system components.
- Their correct (or incorrect) function cannot cause an inadvertent firing.

Concluding Remarks

Is this a perfect firing system? No. There is always room for improvement. Lighted switches or similar features could be added to provide feedback on the health of all components. Support for firings at multiple launch pads could be included. Support for the fueling of hybrids and/or liquids could be required. A wireless data link could provide convenient and easy to set up communications at greater ranges. The list of desired features is going to be heavily situation dependent and is more likely to be limited by money than good ideas.

The circuit should be designed such that no single equipment failure can result in the inadvertent firing of the e-match and thus, the rocket motor. Whether or not a particular circuit is applicable to any given scenario is beside the larger point that in the event of any single failure a firing system should always fail-safe and never fail in a dangerous manner. No matter how complicated the system may be, it should be analyzed in depth and the failure of any single component should never result in the firing of a rocket during an unsafe range condition. Note that this is the bare minimum requirement; ideally, a firing system can handle multiple failures in a safe manner.

APPENDIX D: AIRSTART IGNITION WIRING DIAGRAM

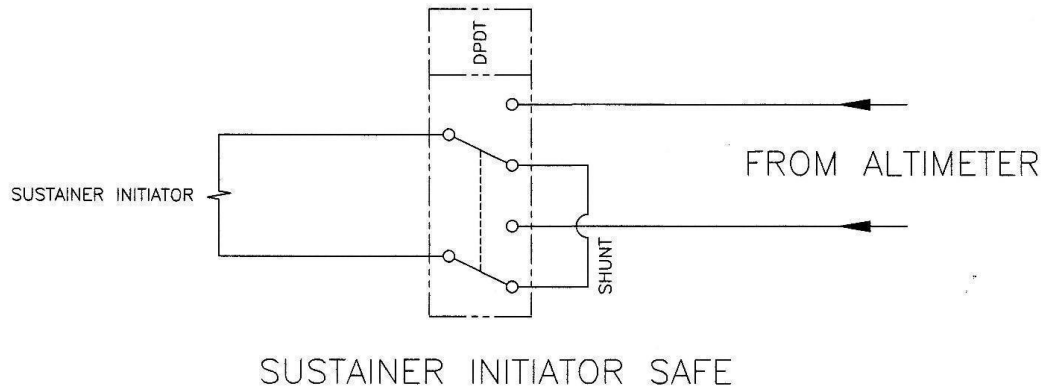
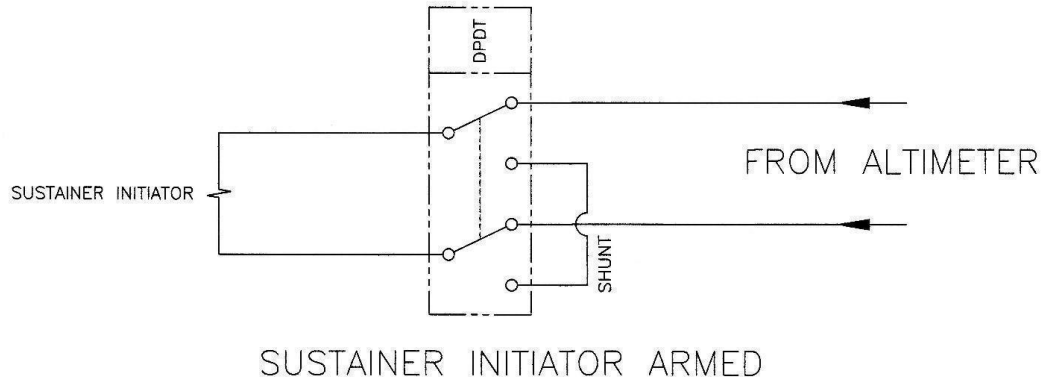

APPENDIX E: ESRA & TRIPOLI ROCKET ASSOCIATION PARTNERSHIP

Summary

The Experimental Sounding Rocket Association (ESRA) and the Tripoli Rocketry Association (TRA) are now formally working together to continue to improve overall flight safety and efficient flight operations at the annual IREC. In addition, student teams flying in the Commercial Off the Shelf (COTS), Student Research and Design SOLID (SRAD SOLID) categories, along with both COTS and SRAD hybrid motors will begin flying under TRA Unified Safety Code. Details of how this impacts competing teams are described below.

Background

TRA and ESRA share common goals to create safe and exciting launch opportunities for the next generation of Aerospace engineers as they progress from hobby to industry environments. Our organizations are highly aligned: ESRA provides the educational framework and administration of the world's largest international collegiate rocketry event; and TRA provides the safety/flight operations framework, incredible membership expertise and an amazing insurance program. Stated simply, we have assembled outstanding partners to build and safely operate the greatest rocketry competition in history.

The IREC has relied on the TRA Unified Safety Code and membership expertise/guidance to create a safe launching environment for its event since 2017. IREC's Range Safety and Launch Operations teams are filled with a significant number of Senior Level 3 high power rocketry experts (>30). A growing number of competing teams utilize TRA prefectures for mentorship, certification flights and test flights of their competition projects.

Benefits:

- **Student Team Liability Insurance** - In previous years, students were either insured by their university or through a 3rd party insurance provider. By becoming a TRA student member and following the TRA Unified Safety Code, the student is insured by TRA's insurance program. TRA insurance covers COTS and SRAD solid and hybrid flights. TRA insurance DOES NOT cover liquid teams or flights.
- Teams flying liquid motors will have to provide their own insurance and submit proof of insurance to ESRA as specified in paragraph 2.6.6.2 of the IREC Rules and Requirements document.
- Student teams will have improved access to TRA mentors, certifications, and launch sites - TRA has a growing list of US and international prefectures with active launch sites. Student teams are highly recommended to engage with their local TRA prefectures for mentoring, certification flights and additional launch experience.

Tripoli Flight Requirements for All Solid and Hybrid Categories:

- A TRA-certified Level 3 Flyer of Record shall be required for all solids and hybrids categories and must be present for launch preparation, pad loading and recovery activities. There are three options to satisfy the requirement for a Level 3 certified Flyer of Record.
- Recommended - each team will secure a TRA Level 3 certified Senior mentor who works closely with the team and is present as the Flyer of Record for the launch preparation, pad loading and recovery activities. Student teams ARE HIGHLY RECOMMENDED to subsidize the travel expenses of their Flyer of Record or mentor, both to and from the event.
- Also recommended - team will have a TRA Level 3 certified student member onsite for the launch preparation, pad loading and recovery activities. The student L3 member will be the Flyer of Record and must be onsite with the team for all aspects of launch.
- International Teams should begin their FoR search immediately and utilize social media platforms, forums and other community outlets to secure a Flyer of Record. ESRA WILL NOT BE PROVIDING L3 FoR's.
- TRA membership is required to be on the range or to work on safety-related systems on the rocket.
- Motors or energetic materials may only be possessed or handled by TRA members with appropriate high power rocketry certification.
- Student teams flying in all solid and hybrid categories are required to meet all TRA launch safety requirements to ensure TRA insurance covers their flight.

TRA Student Membership

- TRA Student membership is \$20 per year per student. This is a requirement for ANY student who will be at launch site.
- A maximum of 5 additional team members who are TRA student members may be on the pad loading team or recovery team. These student team members do not have to be HPR certified but must be TRA student members. All students are highly recommended to secure HPR certification

Questions:

- **Why are we making this change?**
 - One of ESRA's primary goals is to foster a healthy engineering competition by conducting the IREC.
 - Our desire is also to find ways to minimize costs to student teams.
 - Put simply, there has been no widely available and cost effective insurance solution for student teams.
 - Working with TRA and formally adopting the requirements above permits teams to be covered by the TRA insurance policy for solid and hybrid rockets.
- **Why are liquid rockets excluded from this policy change?**

- TRA brings world-class expertise in the area of solid and hybrid rocket motors.
- The policies and rules for these motors are well established with a robust system of mentors and specific certification levels.
- Liquid rockets are inherently more complex with dangers and risks that are substantially different from solid motors. Accordingly, TRA insurance does not cover these rockets, and teams must provide proof of adequate insurance to ESRA prior to the competition.
- ESRA is committed to continuing to search for viable means to support the establishment of such an organization to provide similar expertise for liquid rockets.

APPENDIX F: EXAMPLE BOOSTER AIRFRAME MARKINGS

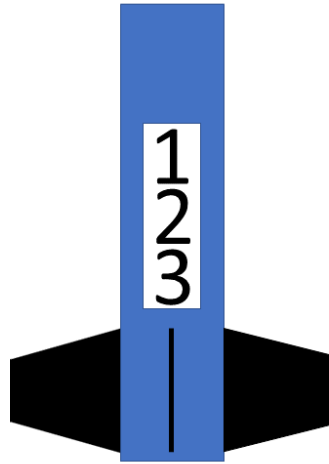

IREC Team ID Number 123 on a 4 fin, 6-inch diameter rocket

APPENDIX G: STANDARD WEATHER CONDITIONS

The following weather conditions are standard at the launch site:

Weather Parameter

Temperature	Min: 17° C (63° F) Max: 35° C (95° F) typical	Can get as high as 46° C (115° F)
Humidity	Average: 27%	As low as 5%
Windspeed	Average: 13 km/h (8 mph)	Gusts: 56+ km/h (35+ mph)
Precipitation	Month Average: 1.25mm (0.05 in)	Occasional heavy rain affecting road access to the launch area.
UV Index	Average Max: 7	
Dust	Everywhere	
Background Noise at Pad	76 dBA (typical)	ESRA generator with no wind

Historical AWOS weather observations can be accessed here:

<https://www.dropbox.com/sh/swi7jrl14evqmap/AADW6GMViv87KkOBY1-flsoIa>

APPENDIX H: DOCUMENT REVISIONS

REVISION	DESCRIPTION	DATE
2024 v1.1.3	<p>Initial Release for 2025 IREC competition</p> <ol style="list-style-type: none"> Added note regarding use of a flight computer for competition scoring and the ESRA recommendation of the Featherweight Altimeters Blue Raven for this function in anticipation of this becoming a requirement beginning with the 2026 IREC competition. Changed logo on title page to IREC logo 	10/22/24
2024 v1.1.2	<ol style="list-style-type: none"> Updated IREC definition to be “International” instead of “Intercollegiate” Removed reference to specific host city/organization in Intro Set release date to 0-21-24 	10/21/24
2024 v1.1.1	<ol style="list-style-type: none"> Generalized event references to IREC Added section on igniters Updated thrust-to-weight calculation to require the calculation to use the average thrust over the first 1 second of operation 	10/10/24
2024 v1.1.0	<ol style="list-style-type: none"> Incorporated feedback from Sims, Russell(s), ... from the Slack channel Removed prohibition on WiFi and magnetic switches 	
2024 v1.0.0	<ol style="list-style-type: none"> Complete review of document incorporating input from Overton, Jarvis, Herrera for the 2025 competition 	10/3/2024
2023 v2.2.9	<ol style="list-style-type: none"> Added AIM XTRA to table in section 4.1.3 Fixed section reference in section 5.2.2 Clarified language in section 8.5 Corrected language in section 10.3.1 	
2023 v2.2.8	<ol style="list-style-type: none"> Complete rewrite, initial release for 2024 IREC 	Oct 2023
2023 v1.4	<ol style="list-style-type: none"> Added Creative Commons v4 Licensing Sections 6.1 and 6.8 rewritten to clarify Redundant Electronics requirements, particularly for Tender Descenders and similar systems. 	Apr 2023
2023 V1.3	<ol style="list-style-type: none"> Initial version for the 2023 IREC. Edits to the 2022 version throughout for clarity and grammar HAM changed to “Amateur Radio” throughout 	Dec 2022

	<ol style="list-style-type: none">4. TRA added to revision process in 1.65. Sections 3.1 and 3.2 rewritten to comply with new TRA MOU6. Changed title on 4.2 to “Multiple GPS Trackers”7. Added BRB900 to chart in 4.38. Changed “transmit rep” to “transmit repeat” in 4.7.3.9. Added recommendation to flight-test SRAD GPS systems in 4.7.510. Added reference to COTS hybrid motors in 5.411. Added new section 5.6 specifying allowable sugar motor materials12. Added new section 5.7 specifying allowable case materials and components for SRAD motors, renumbered subsequent paragraphs13. Added dual igniter requirement in 5.9 and renumbered subsequent paragraphs14. Moved air-start thrust-to-weight requirements in 5.10 to 5.14 and renumbered subsequent paragraphs15. Added clarification to hybrid remote venting requirement in 5.1216. Changed requirement in 5.17 to 70% of planned altitude for tilt lockout systems. Other systems remain at 80%.17. Changed deadline in 5.19.2 to 1 May for completion of SRAD propulsion testing and made it a hard deadline.18. Added openMotor to 5.22.119. Added requirement in 5.22.2 to provide a CSV file with SRAD propulsion testing data.20. Added advisory in 6.1 stating that rockets can’t be retrieved from WSMR property.21. Clarified 6.11 – 6.13 language on safety critical wiring to match updated Appendix B.22. Added new 8.2.3 specifying that maximum velocity is at least 50% higher than fin flutter velocity.23. Clarified 8.3 and 8.4 to make it clear that stainless steel components can be used for all parts of the recovery system and are only prohibited from use as airframes or motor casings.24. Clarified 8.5 to specify that the required one caliber overlap applies only to airframe joints and added requirement for nose cone and boat tail shoulders to be at least 0.5 calibers.25. Added specifications in 8.8.2 for team ID numbers on the airframe.	
--	---	--

	<ul style="list-style-type: none">26. Added clarification in 10.2.5, reminding teams to account for rail button location when determining rail exit velocity.27. Added 11.3.2 requiring hybrid teams to have a method to remotely monitor oxidizer fill.28. Updated acronyms in Appendix A.29. Updated “excessive damage” definition in Appendix A to include consideration for readily replaceable airframe components.30. Updated Appendix B for clarity.31. Appendix E rewritten to match wording in 3.1 and 3.232. Added new Appendix F with example booster markings33. Format changes throughout for consistency	
Baseline	Rev 1.0 Draft	Sep 2022